

VistaVox S and VistaVox S Ceph



EN Operating Instructions

The current version of the installation and operating instructions is available in the Download Center:



<https://qr.duerdental.com/2210200845>

Contents



Important information

1 About this document	3
1.1 Warnings and symbols	3
1.2 Copyright information	4
2 Safety	5
2.1 Intended purpose	5
2.2 Intended use	5
2.3 Improper use	5
2.4 Contraindication	5
2.5 General safety information	5
2.6 Radiation protection	5
2.7 Specialist personnel	6
2.8 Electrical safety	6
2.9 Essential performance characteristics	7
2.10 Notification requirement of serious incidents	7
2.11 Only use original parts	7
2.12 Transport	7
2.13 Disposal	7
2.14 Protection from threats from the Internet	7



Product description

3 Overview	8
3.1 VistaVox S	8
3.2 VistaVox S Ceph	9
3.3 Scope of delivery	10
3.4 Accessories	10
3.5 Optional items	10
3.6 Consumables	11
4 Technical data	12
4.1 X-ray tube performance data	13
4.2 Dimensions	16
4.3 Type plate	20
4.4 Evaluation of conformity	20
5 Operation	21
5.1 3D and panoramic X-ray unit	21

5.2 Cephalometric projections unit	21
5.3 Operating elements	21
5.4 Status LED	22
5.5 Positioning aids for 3D and panoramic image	22
5.6 Positioning aids for cephalometric projections	23
5.7 Exposure button	23
5.8 Memory card slot	24
5.9 Sensor window	24



Usage

6 Operating the touch screen	25
6.1 Navigating	25
6.2 Using menus	25
6.3 Calling up messages on the touch screen	25
7 Operation	26
7.1 Switch on the unit	26
7.2 Adjusting the imaging software	27
7.3 Panoramic X-ray unit	34
7.4 Positioning the patient	39
7.5 Cephalometric exposures	42
7.6 Start a test run	45
7.7 Taking the X-ray image	45
7.8 Emergency stop switch	46
8 Cleaning and disinfection	48
8.1 Unit surfaces	48
8.2 Positioning aids	48
9 Reprocessing	50
9.1 Risk analysis and categorisation	50
9.2 Preparation process in accordance with ISO 17664	50
9.3 General information	51
9.4 Preparation at the operating location	51
9.5 Manual cleaning, intermediate rinsing, disinfection, final rinse, drying	52

- 9.6 Automatic cleaning, intermediate rinsing, disinfection, final rinse, drying 52
- 9.7 Check for function 52
- 9.8 Steam sterilising 53
- 9.9 Issue clearance for the parts for sterilisation 53
- 9.10 Storing parts for sterilisation 53
- 10 Maintenance 54**
 - 10.1 Recommended maintenance schedule 54



Troubleshooting

- 11 Tips for operators and service technicians 55**



Appendix

- 12 Program parameters 57**
 - 12.1 CBCT program parameters 57
 - 12.2 Panoramic program parameters 58
 - 12.3 Programme parameters for cephalometric projections 58
- 13 Information on scattered radiation 60**
 - 13.1 CBCT scattered radiation 60
 - 13.2 Pano scattered radiation 60
- 14 Information on the leakage rate 61**

Important information

1 About this document

These installation and operating instructions form part of the unit.

 If the instructions and information in these operating instructions are not followed, Dürr Dental will not be able to offer any warranty or assume any liability for the safe operation and the safe functioning of the unit.

The German version of the operating instructions is the original manual. All other languages are translation of the original manual.

These operating instructions apply to:

VistaVox S

REF: 2210200653

VistaVox S Ceph

REF: 2210200575

Hygienic protective covers for bite block

REF: 2207-010-50.

Refer to the separate installation instructions for information about assembly, installation and configuration of the unit.

1.1 Warnings and symbols

Warnings

The warnings in this document are intended to draw your attention to possible injury to persons or damage to machinery.

The following warning symbols are used:



General warning symbol



Warning – dangerous high voltage

The warnings are structured as follows:



SIGNAL WORD

Description of the type and source of danger

Here you will find the possible consequences of ignoring the warning

- › Follow these measures to avoid the danger.

The signal word differentiates between four levels of danger:

- **DANGER**
Immediate danger of severe injury or death
- **WARNING**
Possible danger of severe injury or death
- **CAUTION**
Risk of minor injuries
- **NOTICE**
Risk of extensive material/property damage

Other symbols

These symbols are used in the document and on or in the unit:



Note, e.g. specific instructions regarding efficient and cost-effective use of the unit.



Medical device



Order number



Serial number



CE labelling with the number of the notified body



Manufacturer



Authorised representative for Switzerland



Dispose of correctly in accordance with EU Directive 2012/19/EU (WEEE).



Type BF application part



Do not reuse



Not sterile







Steam sterilise at 134 °C



Protective ground connection



Equipotential bonding

-  Fragile, handle with care
-  Lower and upper atmospheric pressure limits
-  Lower and upper temperature limits
-  Lower and upper humidity limits

 Stacking limits

 Recycling

 Keep dry

 This way up / store and transport in an upright position

 Keep away from sunlight

 Refer to Operating Instructions.

 Wear protective gloves.

 Wear protective goggles.

 Use protective clothing.

 Use a mask.

 Disconnect all power from the unit.

 Notice

 Emergency stop switch

 Laser class 1

 Warning – X-rays

 Warning – dangerous high voltage

1.2 Copyright information

All circuits, processes, names, software programs and units mentioned in this document are protected by copyright.

The Installation and Operating Instructions must not be copied or reprinted, neither in full nor in part, without written authorisation from the copyright owner.

2 Safety

The unit has been developed and designed in such a way that dangers are effectively ruled out if used in accordance with the Intended Use. Despite this, the following residual risks can remain:

- Personal injury due to incorrect use/misuse
- Personal injury due to mechanical effects
- Personal injury due to electric shock
- Personal injury due to radiation
- Personal injury due to fire
- Personal injury due to thermal effects on skin
- Personal injury due to lack of hygiene, e.g. infection

2.1 Intended purpose

Unit

Creation of 3D, pano and optionally cephalometric X-ray images in dental radiography for adult and adolescent patients.

Hygienic protective covers

Hygienic protective covers are intended to be used as a disposable barrier for dental instruments equipment and accessories.

2.2 Intended use

Unit

The unit must only be used by dentists or dental assistants who have been trained in the use of X-ray radiation in accordance with the applicable legal requirements.

Bite block

The devices are intended to be used in the oral cavity of the patient. The foam part of the bite block comfort is a single-use device. The other devices and components are reusable and must be sterilized by the user before use.

Other positioning aids

The positioning aids are intended for repeated use.

The positioning aids are not sterile and should be cleaned and disinfected prior to use.

Hygienic protective covers

Hygienic protection covers are nonsterile and intended for single patient use only.

2.3 Improper use

Any use of this appliance / these appliances above and beyond that described in the Installation and Operating Instructions is deemed to be incorrect usage. The manufacturer cannot be held liable for any damage resulting from incorrect usage. The operator will be held liable and bears all risks.

2.4 Contraindication

The radiobiological effects of X-ray beams in tissue result in the following contraindications:

- Pregnancy
- Pre-existing illnesses preventing the recording of a CBCT image
- Absence of a justified indication

Exceptions can be formulated at the discretion of the physician.

2.5 General safety information

- › Always comply with the specifications of all guidelines, laws, and other rules and regulations applicable at the site of operation for the operation of this unit.
- › Check the function and condition of the unit prior to every use.
- › Do not convert or modify the unit.
- › Comply with the specifications of the Installation and Operating Instructions.
- › The Installation and Operating Instructions must be accessible to all operators of the unit at all times.

2.6 Radiation protection

- › Comply with all applicable X-ray protection rules and take all required X-ray protection measures.
- › Use the prescribed X-ray protection equipment.
- › In order to reduce the level of X-ray exposure, we recommend the use of bismuth, lead shielding or protective aprons, especially for children and teenagers.
- › The persons operating the equipment must keep away from the X-ray unit while the exposure is being taken. The minimum distance required by law must be maintained (e.g. Germany 1.5 m, Austria 2.0 m).
- › Children and pregnant women must consult a doctor before having an X-ray taken.

- › Nobody else must be in the radiation room without X-ray protection measures apart from the patient. In exceptional circumstances another person may be present to provide assistance, but this must not be a member of the surgery staff. When the exposure is being taken, make sure that you maintain visual contact with the patient and the unit and keep talking to the patient.
- › The radiation room must be lockable to prevent entry by unauthorised persons.
- › If a fault occurs, cancel the exposure immediately by letting go of the trigger button.

2.7 Specialist personnel

Operation

- Unit operators must use their training and knowledge to ensure safe and correct handling.
- › Instruct or have every operator instructed in the handling of the unit.

Installation and repairs

- › Have the manufacturer or a qualified company authorised by the manufacturer perform mounting, new installations, modifications, expansions and repairs.

2.8 Electrical safety

- › Comply with all the relevant electrical safety regulations when working on the unit.
- › Never touch the patient and unshielded plug connections on the device at the same time.
- › Replace any damaged cables or plugs immediately.

Observe the EMC rules concerning medical devices

- › The unit is intended for use in professional healthcare facilities (in accordance with IEC 60601-1-2). If the appliance is operated in another environment, potential effects on electromagnetic compatibility must be taken into account.
- › Do not operate the unit in the vicinity of HF surgical instruments or MRT equipment.
- › Maintain a minimum distance of at least 30 cm between the unit and other electronic devices.
- › Note that cable lengths and cable extensions have effects on electromagnetic compatibility.
- › No maintenance measures are required to maintain the EMC basic safety.

- › The emissions characteristics of this device render it suitable for use in industrial environments and hospitals (CISPR 11, Class A). When used in a residential environment (which normally requires Class B in accordance with CISPR 11), this device may not provide adequate protection from radio communication services. The operator may need to take corrective measures such as relocating or reorienting the device.



NOTICE

Negative effects on the EMC due to non-authorised accessories

- › Use only those accessories named or approved by the manufacturer.
- › Using any other accessories may result in increased electromagnetic interference emissions or the unit having reduced electromagnetic immunity, leading to an erroneous operation mode.



NOTICE

Erroneous operation mode due to use immediately adjacent to other devices or with other stacked devices

- › Do not stack the unit together with other devices.
- › If this is unavoidable, the unit and other devices should be monitored in order to ensure that they are working correctly.



NOTICE

Reduced performance characteristics due to insufficient distance between unit and portable HF communication devices

- › Keep a distance of at least 30 cm between the unit (including parts and cables of the unit) and portable HF communication devices (wireless units) (including their accessories such as antenna cables and external antennas).

2.9 Essential performance characteristics

The unit does not have any essential performance characteristics as set out in IEC 60601-1 section 4.3.

The unit complies with the requirements according to IEC 60601-1-2:2014.

2.10 Notification requirement of serious incidents

The operator/patient is required to report any serious incident that occurs in connection with the device to the manufacturer and to the competent authority of the Member State in which the operator and/or patient is established/resident.

2.11 Only use original parts

- › Only use accessories and optional items that have been recommended or specifically approved by Dürr Dental.
- › Only use only original wear parts and replacement parts.



The manufacturer and distributor accept no liability for damages or injury resulting from the use of non-approved accessories, optional accessories, or from the use of non-original wear parts or replacement parts.

The use of non-approved accessories, optional accessories or non-genuine wear parts / replacement parts (e.g. mains cables) can have a negative effect in terms of electrical safety and EMC.

The following accessories can influence EMC:

- Mains cable (3.6 m; order no.: 2210200243)
- Exposure switch (order no.: 2210200313)

2.12 Transport

The original packaging provides optimum protection for the unit during transportation.

If required, the original packaging for the unit can be ordered.



The manufacturer and the distributor do not accept liability, even during the warranty period, for damage during transportation due to improper packaging.

- › Only transport the unit in its original packaging.

- › Keep the packing materials out of the reach of children.
- › Reattach the transport locking devices.
- › Do not expose the unit to any strong vibrations or shocks.

Do not bump or pull the unit.

2.13 Disposal



An overview of the waste keys for Dürr Dental products can be found in the download area:



<http://qr.duerrdental.com/P007100155>

Unit



The unit must be disposed of properly. Within the European Union, the unit must be disposed of in accordance with EU Directive 2012/19/EU (WEEE).

X-ray emitter

The X-ray unit contains a tube that is potentially capable of imploding, lead cladding and mineral oil.

2.14 Protection from threats from the Internet

The unit is to be connected to a computer that can be connected to the Internet. Therefore, the system needs to be protected from threats from the Internet.

- › Use antivirus software and update it regularly. Look for evidence of possible virus infection and, if applicable, check with the antivirus software and remove the virus.
- › Perform regular data backups.
- › Restrict access to units to trustworthy users, e.g. via a user name and password.
- › Make sure that only trustworthy content is downloaded. Only install software and firmware updates that have been authenticated by the manufacturer.

Product description

3 Overview

3.1 VistaVox S

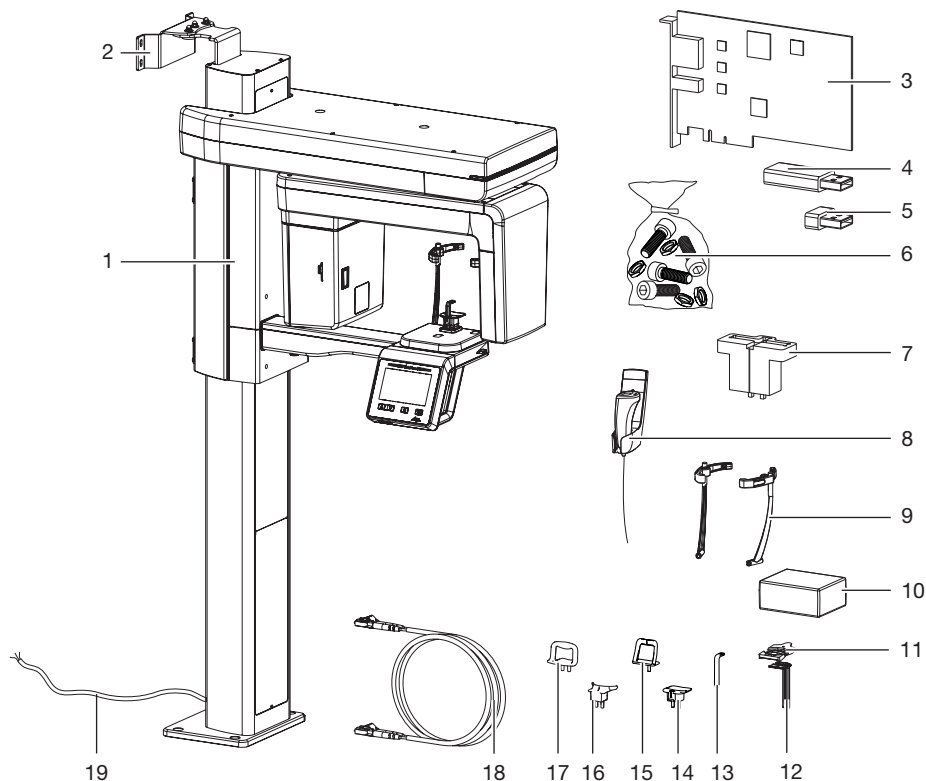

- | | | | |
|---|---------------------------------------|----|---------------------------------------|
| 1 | 3D and panoramic X-ray device | 9 | Head support Plus with cushion |
| 2 | Wall bracket | 10 | Hygienic protective bite covers |
| 3 | Framegrabber 3 | 11 | Comfort bite foam |
| 4 | USB Dongle for 3D reconstruction | 12 | Comfort bite holder |
| 5 | USB flash drive with calibration data | 13 | Bite block |
| 6 | Small parts | 14 | Holder for bite block |
| 7 | Pano test phantom holder | 15 | Chin holder for maxillary joint image |
| 8 | Exposure switch (with holder) | 16 | Chin holder for edentulous jaws |
| | | 17 | Chin holder for sinus image |
| | | 18 | Optical fiber |
| | | 19 | Mains cable for permanent connection |

3.2 VistaVox S Ceph

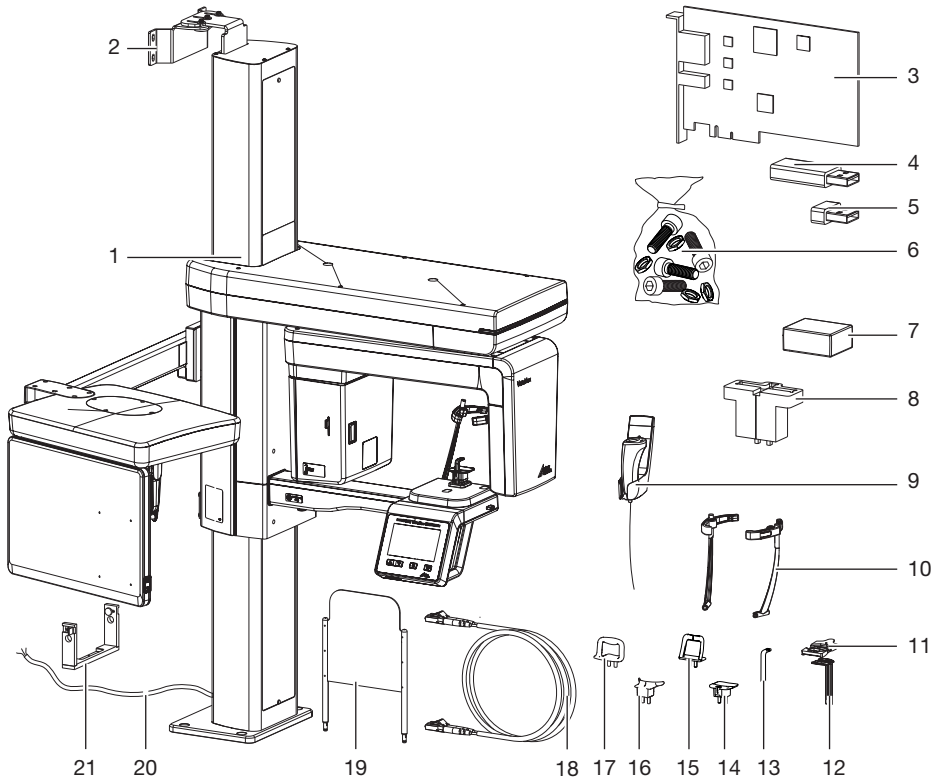

- 1 3D, Ceph and panoramic X-ray device
- 2 Wall bracket
- 3 Framegrabber 3
- 4 USB Dongle for 3D reconstruction
- 5 USB flash drive with calibration data
- 6 Small parts
- 7 Hygienic protective bite covers
- 8 Pano test phantom holder
- 9 Exposure switch (with holder)

- 10 Head support plus with cushion
- 11 Comfort bite foam
- 12 Comfort bite holder
- 13 Bite block
- 14 Holder for bite block
- 15 Chin holder for maxillary joint image
- 16 Chin holder for edentulous jaws
- 17 Chin holder for sinus image
- 18 Optical fiber
- 19 Positioning plate for carpus projections
- 20 Mains cable for permanent connection
- 21 Ceph test phantom holder

3.3 Scope of delivery

The following items are included in the scope of delivery (possible variant-specific deviations due to country-specific requirements and/or import regulations):

VistaVox S

VistaVox S 2210200726

- Fibre optic cable 10 m
- Exposure switch and holder
- Holder for bite block
- Bite block (3 pcs)
- Comfort bite holder (3 pcs)
- Comfort bite foam (10 pcs)
- Chin holder for edentulous jaws
- Chin holder for maxillary joint image
- Chin holder for sinus image
- Head support plus with cushion
- Hygienic protective bite covers (100 pcs)
- Pano test phantom holder (Germany, Austria, Swiss, France)
- Top wall bracket set, short
- Set of small parts (e.g. screws, nuts etc.)
- Various housing parts
- Voucher for VistaSoft imaging software
- Operating instructions
- Installation instructions
- X-ray control book (Germany, Austria, Swiss, France)
- Framgrabber 3
- USB dongle for 3D reconstruction
- USB flash drive with calibration data

VistaVox S Ceph

VistaVox S Ceph 2210200728

- Fibre optic cable 10 m
- Exposure switch and holder
- Holder for bite block
- Bite block (3 pcs)
- Comfort bite holder (3 pcs)
- Comfort bite foam (10 pcs)
- Chin holder for edentulous jaws
- Chin holder for maxillary joint image
- Chin holder for sinus image
- Head support plus with cushion
- Hygienic protective bite covers (100 pcs)
- Pano test phantom holder (Germany, Austria, Swiss, France)
- Ceph test phantom holder (Germany, Austria, Swiss, France)
- Top wall bracket set, long
- Positioning plate for carpus projections
- Ear rod holder set
- Nasal support set
- Set of small parts (e.g. screws, nuts etc.)
- Various housing parts
- Voucher for VistaSoft imaging software
- Operating instructions
- Installation instructions
- X-ray control book (Germany, Austria, Swiss, France)
- Framgrabber 3
- USB dongle for 3D reconstruction
- USB flash drive with calibration data

 If the mains cable of this unit is damaged it must only be replaced by an original mains cable from the manufacturer.

3.4 Accessories

The following items are required for operation of the device, depending on the application:

Hygienic protective bite covers (100 pcs) 2207-010-50

3.5 Optional items

The following optional items can be used with the device:

Cushion for head support plus . . . 2210200701

Lower wall bracket set, long (wall/wall installation) 2210200439

Fibre optic cable 5 m	2210200758
Fibre optic cable 20 m	2210200759
Ceph test phantom holder (Germany, Austria, Swiss, France)	2130-996-00

Positioning aids

Holder for bite block	2210200918
Bite block (3 pcs)	2210201074
Chin holder for edentulous jaws . .	2207-052-50
Head support plus with cushion . .	2210200700
Chin holder for maxillary joint image	2207-053-50
Chin holder for sinus image	2207-054-50
Comfort bite holder (3 pcs)	2210201075
Comfort bite foam (100 pcs)	2210201067

Acceptance and consistency check

2-D X-ray Test phantom set	2121-060-55
Consistency test phantom 3D set .	2210200527
Acceptance test phantom 3D	2210200526
Ball phantom	2207-021-50
Primary absorber set Pano/Ceph . .	2207100047
Pano test phantom holder (Germany, Austria, Swiss, France)	2207-900-50
X-ray control book (Germany, Austria, Swiss, France)	9000-618-245

VistaVox S only

Lower wall bracket set, short	2210200553
Top wall bracket set, long	2210200611

VistaVox S Ceph only

Pedestal for Ceph variant	2210200634
Silicone pads for ear rods and nasal support set	2210200956

3.6 Consumables

The following materials are consumed during operation of the device and must be ordered separately:

Hygienic protective bite covers (100 pcs)	2207-010-50
Cushion for head support plus . . .	2210200701

VistaVox S Ceph only

Silicone pads for ear rods and nasal support set	2210200956
--	------------

Cleaning and disinfection

FD 350 Classic disinfection wipes	CDF35CA0140
---	-------------

FD 333 rapid surface disinfection	CDF333C6150
FD 322 rapid surface disinfection	CDF322C6150
ID 215 Enzymatic instrument cleaner	CDI220C6150
ID 212 Instrument disinfection	CDI212C6150
FD 366 rapid disinfectant for sensitive surfaces	CDF366C6150



Information about replacement parts is available from the portal for authorised specialist dealers at:
www.duerrdental.net

4 Technical data

Electrical data for the unit		
Rated voltage	V AC	200 - 240
Frequency	Hz	50/60
Protection class		I
Operating mode X-ray tube		S6 = 6.3% 320 s duty cycle 20 s / 5 min (switch-on/switch-off time)
Operating mode height adjustment		S3 = 9% duty cycle 1 min / 9 min (switch-on/switch-off time)
Rated power	W	170
Maximum power	kVA	2.2
Fuses*		T 10.0 AH / 250 V (IEC 60127-2, Sheet 5)

* The fuses must only be replaced by Dürr Dental or by a company authorised by Dürr Dental.

Classification	
Medical Device Class	IIb

General technical data		VistaVox S	VistaVox S Ceph
Dimensions (W x D)	mm	572.5 x 1181 ± 12	1940.8 x 1251 ± 12
	in	22.54 x 46.50 ± 0.47	76.41 x 49.25 ± 0.47
Height	mm	1406 - 2206	1406 - 2206
	in	55.35 x 86.85	55.35 x 86.85
Weight	kg	180	202
	lbs	397	445

Ambient conditions during storage and transport		
Temperature	°C	-10 to +60
	°F	14 to 140
Relative humidity	%	10 - 75
Air pressure	hPa	860 - 1060

Ambient conditions during operation		
Temperature	°C	10 - 35
	°F	50 - 95
Relative humidity	%	30 - 75
Air pressure	hPa	860 - 1060

X-ray emitter	
Model	DG-07E22T2
Rated power	kW 1.6 (for 1 s)
Type: high-voltage generator	Inverter
Rated voltage, high-voltage generator	kV 60 - 99 (±10 %)

X-ray emitter		
Nominal current, high-voltage generator	mA	4 - 16 ($\pm 10\%$, max. 75 kV 16 mA, max. 99 kV 10 mA)
Cooling, high-voltage generator		Automatic monitoring Shut-off at $\geq 60^\circ\text{C}$
Additional filtration	mm Al in Al	1.5 + 3.0 (autom. added for CBCT) 0.06 + 0.12 (autom. added for CBCT)
Inherent filtration	mm Al in Al	0.8 0.03
Total filtration	mm Al in Al	2.5 + 3.0 (autom. added for CBCT) 0.09 + 0.12 (autom. added for CBCT)
X-ray tube model		D-052SB / Canon (Toshiba)
Focal spot size as per IEC 60336 X-ray tube	mm in	0.5 0.02
Anode angle*	$^\circ$	5
Anode heat capacity	kJ	35
Pulse/break ratio		1:60 or more
Duration of radiation exposure	s	0.5 - 20
Maximum current-time product per hour	mAs	960 (with 75 kV/16 mA)

*The reference axis is the perpendicular of the X-ray exit window level with the side marker for the focal point on the cover of the X-ray emitter

4.1 X-ray tube performance data

- Maximum deviation of the peak voltage from the displayed value $\pm 10\%$
- Maximum deviation of the tube current from the displayed value $\pm 20\%$
- Maximum deviation of the exposure time from the displayed value $\pm 10\%$
- The unit complies with the standards IEC 60601-1, IEC 60601-1-3 and IEC 60601-2-63.
- The lowest possible load factor is obtained with a combination of the settings 60 kV and 4 mA.

Maximum Rating Charts

DC (Center Grounded)

Constant potential high-voltage generator
Nominal Focus Spot Value: 0.5

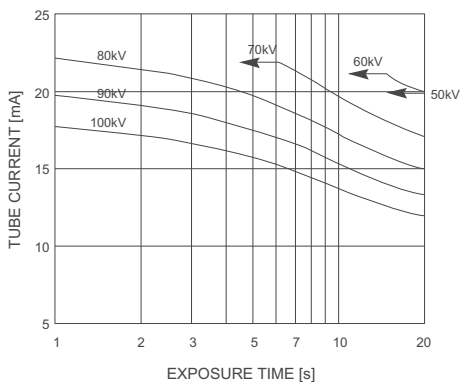

Emission and Filament Characteristics

Constant potential high-voltage generator
Nominal Focus Spot Value: 0.5

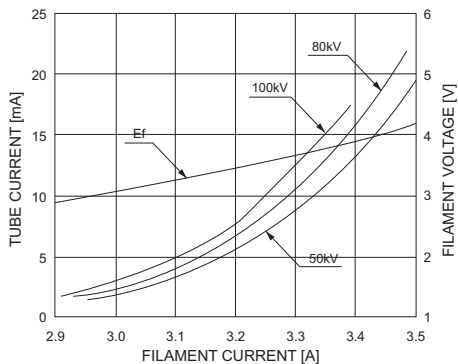

Anode Thermal Characteristics

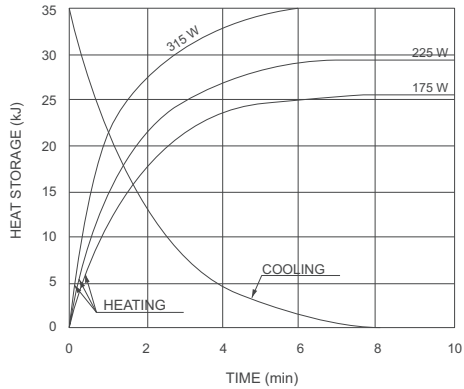

Detector		Panoramic/CBCT	Cephalometric projections
Brand		Xmaru 1404CF	Xmaru 2602CF
Type		CMOS photodiode array	
Pixel size	μm	49.5 99 (2x2 binning) 198 (4x4 binning)	100 200 (2x2 binning)
Sensor size	mm in	230 x 160 x 26 9.06 x 6.30 x 1.02	279 x 110 x 20 10.98 x 4.33 x 0.79
Active surface area	mm in	135.8 x 36.4 5.35 x 1.43	259.2 x 15.6 10.20 x 0.61
Frame rate	fps	53.5 107 (2x2 binning) 308 (4x4 binning)	320
Greyscales	bit		14

Acquisition mode	FDD mm in	FOD mm in	ODD mm in	Magnification factor (magnification factor)
CBCT	600 23.62	428.6 16.87	171.4 6.75	-
Panoramic	600 23.62	477.7 18.81	122.3 4.81	1.26
Cephalometric projections	1745 68.70	1524 60.00	221 8.70	1.14

FDD: distance from focal spot to detector

FOD: distance from focal spot to object

ODD: distance from object to detector (ODD = FDD - FOD)

Magnification factor = FDD/FOD

4.2 Dimensions

VistaVox S

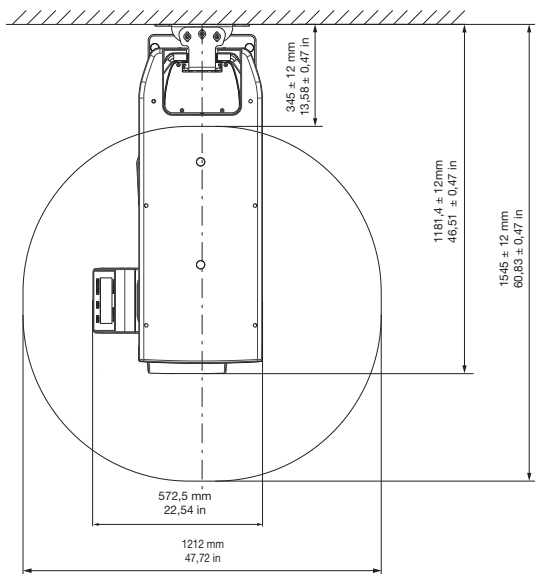
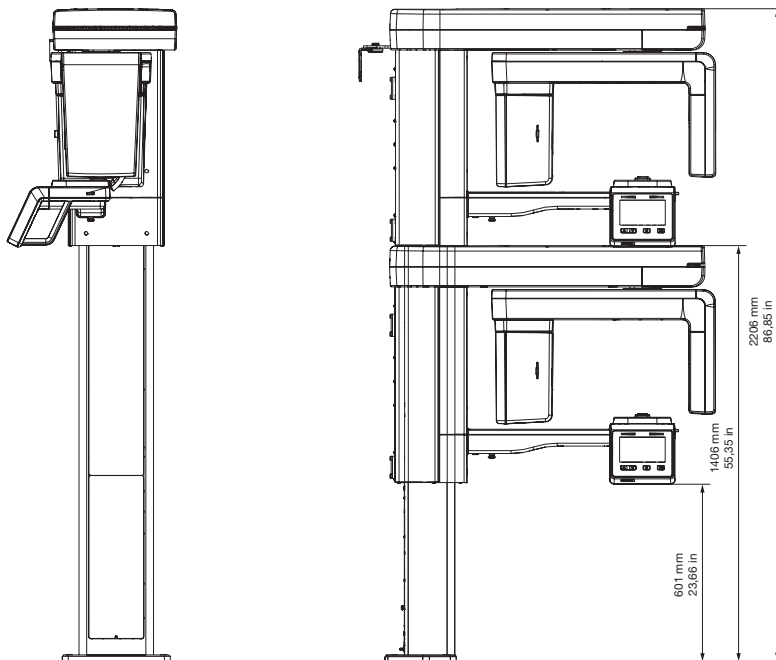

VistaVox S Ceph

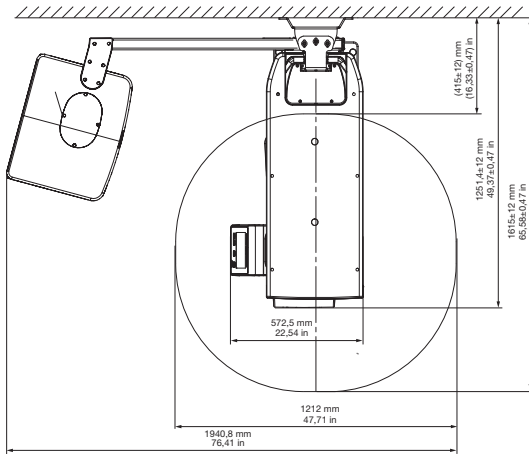
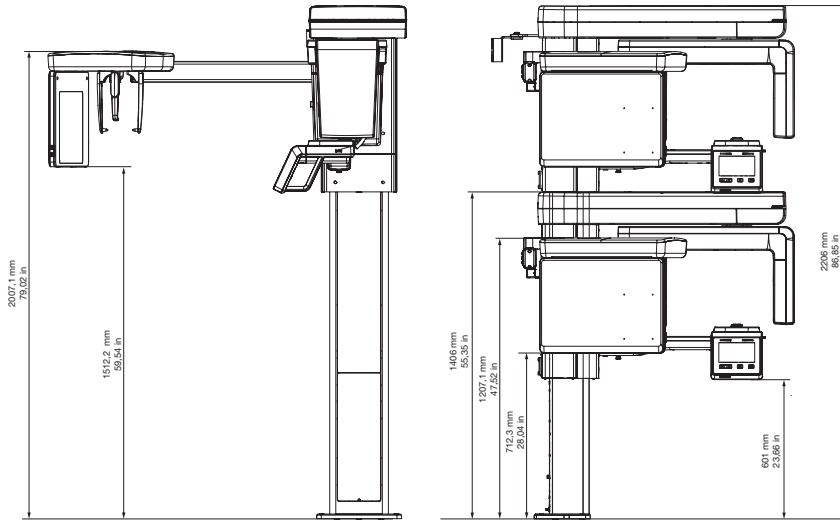

**Electromagnetic compatibility (EMC)
Interference emission measurements**

HF emissions in accordance with CISPR 11	Group 1
Interference voltage at the power supply connection CISPR 11:2009+A1:2010	Class A
Electromagnetic interference radiation CISPR 11:2009+A1:2010	Class A
Emission of harmonics IEC 61000-3-2:2005+A1:2008+A2:2009	Class A
Voltage changes, voltage fluctuations and flicker emissions IEC 61000-3-3:2013	Compliant

**Electromagnetic compatibility (EMC)
Interference immunity measurements cover**

Immunity to interference, discharge of static electricity IEC 61000-4-2:2008 ± 8 kV contact ± 2 kV, ± 4 kV, ± 8 kV, ± 15 kV air	Compliant
Immunity to interference, high-frequency electromagnetic fields IEC 61000-4-3:2006+A1:2007+A2:2010 3 V/m 80 MHz - 2.7 GHz 80% AM at 1 kHz	Compliant
Immunity to interference, near fields of wireless HF communication devices IEC 61000-4-3:2006+A1:2007+A2:2010 See immunity to interference table, near fields of wireless HF communication devices.	Compliant

Immunity to interference table, near fields of wireless HF communication devices

Radio service	Frequency band MHz	Test level V/m
TETRA 400	380 - 390	27
GMRS 460 FRS 460	430 - 470	28
LTE band 13, 17	704 - 787	9
GSM 800/900 TETRA 800 iDEN 820 CDMA 850 LTE band 5	800 - 960	28

Immunity to interference table, near fields of wireless HF communication devices

Radio service	Frequency band MHz	Test level V/m
GSM 1800 CDMA 1900 GSM 1900 DECT LTE band 1, 3, 4, 25 UMTS	1700 - 1990	28
Bluetooth WLAN 802.11 b/g/n RFID 2450 LTE band 7	2400 - 2570	28
WLAN 802.11 a/n	5100 - 5800	9

Electromagnetic compatibility (EMC)**Interference immunity measurements supply input**

Immunity to interference, rapid transient bursts – AC voltage grid

IEC 61000-4-4:2012 ± 2 kV 100 kHz repetition frequency	Compliant
--	-----------

Immunity to interference, line-line

IEC 61000-4-5:2005 ± 0.5 kV, ± 1 kV	Compliant
--	-----------

Immunity to interference by surges, line-earth

IEC 61000-4-5:2005 ± 0.5 kV, ± 1 kV, ± 2 kV	Compliant
--	-----------

Immunity to interference, line-conducted disturbances induced by high-frequency fields – AC voltage grid

IEC 61000-4-6:2013 3 V 0.15 - 80 MHz 6 V ISM frequency bands 0.15 - 80 MHz 80% AM at 1 kHz	Compliant
--	-----------

Immunity to interference due to voltage dips, short interruptions and voltage variations

IEC 61000-4-11:2004 0% U_T for 0.5 period 0% U_T for 1 period 70% U_T for 25/30 periods (50/60 Hz) 0% U_T for 250/300 periods (50/60 Hz)	Compliant
--	-----------

4.3 Type plate

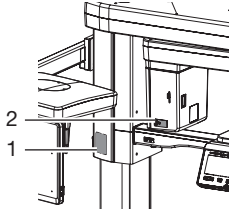

- 1 Unit type plate
- 2 X-ray tube type plate

4.4 Evaluation of conformity

This device has been subjected to conformity acceptance testing in accordance with the current relevant European Union guidelines. This equipment conforms to all relevant requirements.

5 Operation

5.1 3D and panoramic X-ray unit

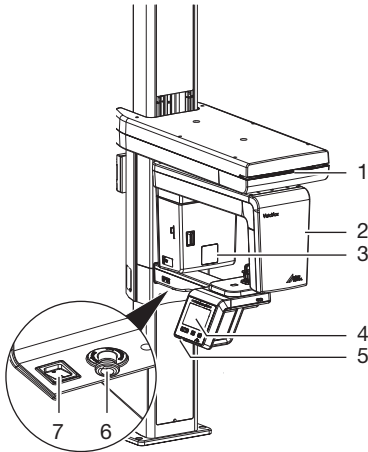

- 1 Status LED
- 2 C-shaped arm
- 3 X-ray tube
- 4 User interfaces
- 5 Memory card slot
- 6 Emergency stop switch
- 7 On/off switch

Similarly to computed tomography or magnetic resonance imaging, sectional images can be generated with CBCT. With CBCT, an X-ray tube and an imaging detector opposite it rotate around a seated or standing patient. The X-ray tube rotates through 180°-540° and emits a conical X-ray beam. The X-ray radiation passes through the region under investigation and is measured for image generation via a detector as an attenuated X-ray image based on grey values. Here, a large series of two-dimensional individual images is acquired during the revolution of the X-ray tube. Using a mathematical calculation on the rotating image series via a reconstruction computer, a grey value coordinate image is generated in the three spatial dimensions. This three-dimensional coordinate model corresponds to a volume graphic that is made up of individual voxels. Based on this volume, it is then possible to generate sectional images (tomograms) in all spatial dimensions as well as 3D views. The X-ray job is started via the imaging software and activated via the touch screen.

5.2 Cephalometric projections unit

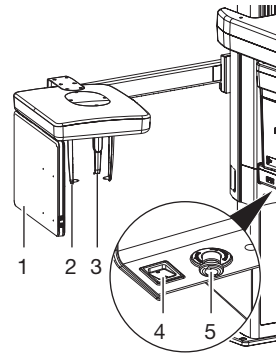

- 1 Sensor (Ceph)
- 2 Ear rods with holder
- 3 Nose support
- 4 On/off switch
- 5 Emergency stop switch

With digital cephalometric projections units, the patient's head is probed line by line with a fan-shaped, flat X-ray beam.

The X-ray task is started via the imaging software and activated via the touch screen.

5.3 Operating elements

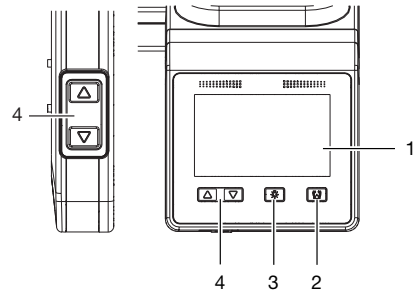

- 1 Touch screen
- 2 Button for opening/closing the head supports
- 3 Button for positioning beam localisers on/off
- 4 Buttons for height adjustment

The touch screen can be used to operate the unit, see also "6 Operating the touch screen". Information can be entered on the touch screen with the tip of a finger.

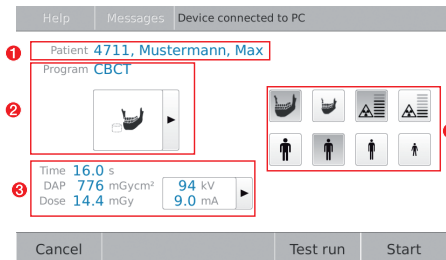
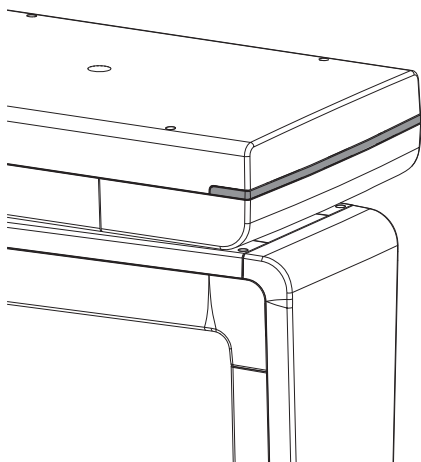

Fig. 1: Monitor, unit ready to acquire image

- 1 Logged-in patient
- 2 Selected X-ray image
- 3 Display of the X-ray parameters (duration, dose, DAP value, voltage and current)
- 4 Selected parameters

The **Messages** button can be used to recall current messages.

5.4 Status LED



The status LED uses different colours to display the different operating modes:

- Blue: unit ready for operation
- Green: unit ready to acquire image
- Yellow: X-ray beam active

5.5 Positioning aids for 3D and panoramic image

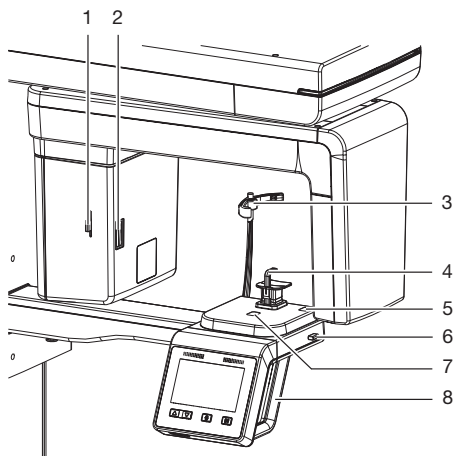

- 1 Lever for positioning the Frankfurt plane positioning beam
- 2 Frankfurt plane of the X-ray positioning beam
- 3 Head support with cushion
- 4 Positioning aid, e. g. chin support with bite block
- 5 Upper canine positioning beam
- 6 Lever for positioning the upper canine positioning beam
- 7 Mid-sagittal positioning beam
- 8 Grips

The positioning aids are used to correctly position the patient in the unit. The suitable positioning aid is selected according to the selected image. The head supports gently keep the head of the patient in place.

Panoramic

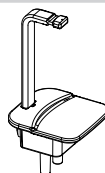

Bite block and holder for bite block

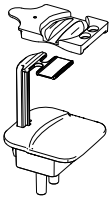
Panoramic

Comfort bite block with foam holder and holder for bite block

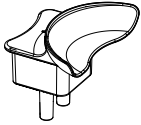

Chin holder for edentulous jaws

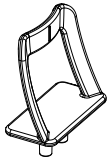

Chin support for maxillary joint image

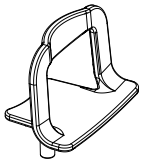

Chin support for sinus image



Head support with cushion

5.6 Positioning aids for cephalometric projections

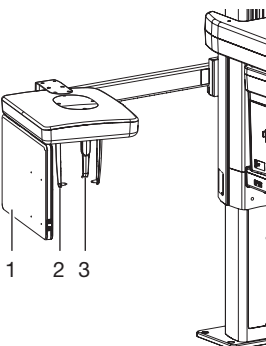

- 1 Sensor (Ceph)
- 2 Ear rods with holder
- 3 Nose support

Cephalometric projections

Ear rods with holder



Nose support

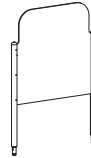

Carpus plate

The applied parts in accordance with IEC 60601-1 are:

- Grips
- Head support with cushion
- Positioning aids (e.g. bite block and mounting for bite block, chin support for edentulous patients)

The applied parts in accordance with IEC 60601-1 for the cephalometric projections unit are:

- Nose support
- Ear rods with holder
- Carpus plate

5.7 Exposure button

Exposure switch

The exposure switch is used to trigger the prepared image acquisition and start the X-ray exposure. The LED indicates the unit status, as does the LED on the unit.

- Green: The unit is ready
- Yellow: X-radiation active

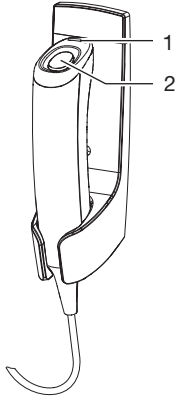

- 1 Indicator lamp (LED)
- 2 Exposure button

5.8 Memory card slot

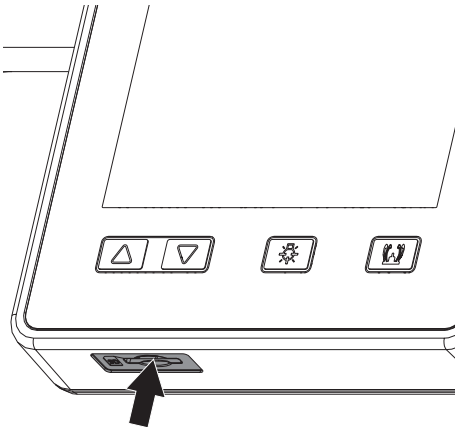

The unit has a slot for a memory card. The slot is only required for service purposes.

5.9 Sensor window

The active sensor surface area is displayed via the markings in the corners of the sensor window. The cross indicates the geometric mid-point of the active sensor surface area.

Panoramic X-ray unit

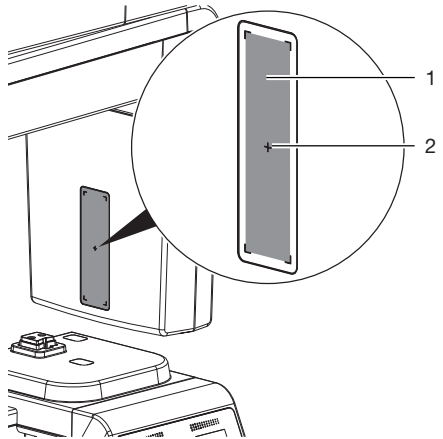

- 1 Active sensor surface area
- 2 Geometric mid-point of the active sensor surface area

Cephalometric projections unit

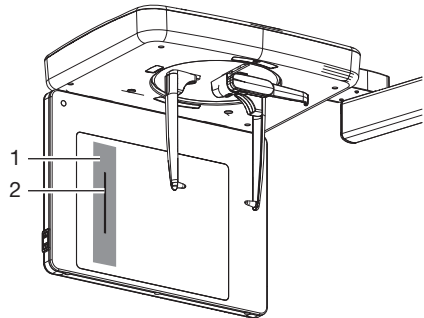

- 1 Line sensor housing
- 2 Active sensor surface area

 Usage

6 Operating the touch screen



NOTICE

Damage to the touch screen due to incorrect handling

- › Only touch the touch screen with your fingertips.
- › Do not use a sharp instrument (e.g. ballpoint pen) to operate the touch screen.
- › Protect the touch screen against water.

- › Operate the touch screen by tapping it with a fingertip to select a button or input field.

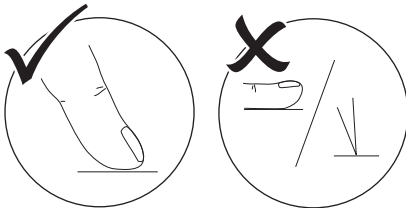



- › For further information about any window tap on the *Help* field.

6.1 Navigating

If the contents of the window cannot be completely displayed on the touch screen, a scroll bar appears.



- › Tap  or  to move the displayed section of the window.

6.2 Using menus

The menus integrated in the main window contain additional commands, which can be selected as required.

- › To open the menu, touch .

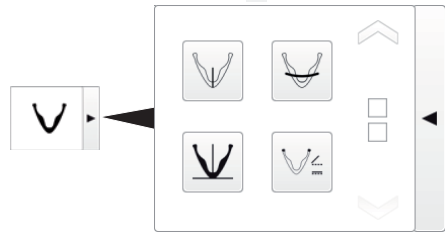



Fig. 2: Example: expanded menu

- › Select a command.

6.3 Calling up messages on the touch screen

The  view on the touch screen displays the current messages.

The *Messages* view under *Settings > Service Menu > Messages* shows the history of all messages that have appeared. Switching to *Access Level Technician* is required.

The messages are divided into the following categories:



Error

Unit will no longer function. When the error has been remedied, it may be necessary to acknowledge the error message.



Warning

After acknowledgement the unit will continue to work, but only with limited functions.



Note

Important information for the operator, e.g. about the current status of the device. The unit continues to operate.



Information

Information for the operator. The unit continues to operate.



Normal operation

› Tap .

The message is displayed. If there are several messages, the most current with the highest priority is displayed first.

› For more information about the message, touch .

7 Operation



In this section, the term "Child" is used to describe children and adolescents from the age of 7.



CAUTION

Health risks for the patient due to contraindications

- › Before using the unit on the patient, check that none of the contraindications listed exist.

7.1 Switch on the unit.



CAUTION

Danger of injury due to movement of the the C-shaped angle connector piece

After switching on the unit and confirming the parameters on the touch screen, the C-shaped angle connector piece is positioned. Persons can be injured during this.

- › Nobody must remain in the area of the C-shaped angle connector piece while the unit is being switched on.

- › Switch on the unit at the main power switch.

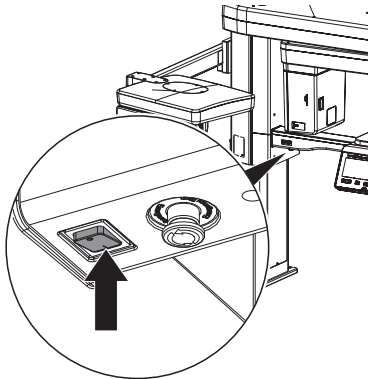

The main power switch lights up green after it is switched on. The status LED lights up blue.

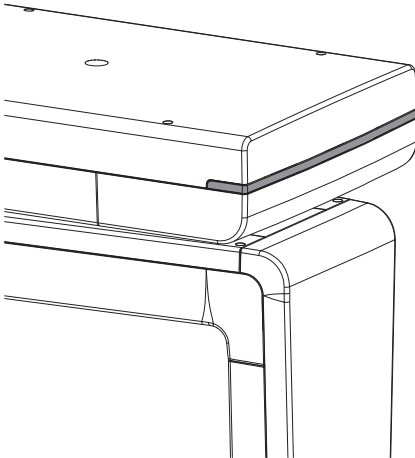

7.2 Adjusting the imaging software





The settings are described using the example of the VistaSoft imaging software.

For further information on using the imaging software, refer to the relevant manual.

Preparing an X-ray image in VistaSoft

Requirements:

- ✓ VistaSoft has been opened.
- ✓ Patient is logged in.
- ✓ No other image acquisitions are in progress (X-ray or video).

- › In the menu bar click on the required image (e.g.  for a CBCT image). Via  you can call up further acquisition types that belong to the grouping e.g.  for 5x5 maxilla molar right (see "Image acquisition programs").



Depending on how the image acquisition types are configured, the acquisition of the X-ray image will start either immediately or you will first need to select an X-ray station.

- › If image acquisition does not begin automatically, select the X-ray station. The parameters, imaging volume and patient shape, are preselected according to the patient.
- › Check the parameters (see also "Parameter overview").

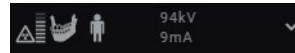

- › Clicking the parameters opens a flyout for editing the parameters. The changed parameters are immediately synchronised with the device.
- › If the preselected parameters are correct, continue to work directly on the unit.

Parameter overview



Depending on the chosen image acquisition program, different parameters are available (e.g. the image volume is not available for panoramic images, but the jaw arch is instead).

Image acquisition volume

The selected image volume influences the height of the image volume. The image volume "Child" has a reduced height. The diameter is identical.



Image volume "Normal"
Size (W x H): approx. 100 x 85 mm



Image volume "Child"
Size (W x H): approx. 100 x 70 mm

Image quality



HQ image
An improved signal/noise ratio is achieved via an extended exposure time.



SQ image
This setting is used for stand-
ard images.

Patient type

Selection of patient type will depend on the patient's size or their head circumference. This means that the preset patient type may need to be changed if necessary.

The X-ray parameters are preset using the patient type (see "Appendix").

If a child is selected then the x-ray parameters are different:

- Reduced dose
- Shorter circulation time
- Smaller radiation field



Tall, well-built patient



Average patient



Small patient



Child (< 13 years)

Arch

The selected jaw form influences the rotational behaviour of the C-shaped angle connector piece during image acquisition. This enables an image with an ideal layer position to be captured even on a particularly narrow or wide jaw.



Normal arch



Narrow arch



Wide arch



Child arch

*Image acquisition programs***CBCT images****CBCT**

The CBCT image shows the jaw area.
The size of the jaw area shown depends on the selected image volume.
Resolution: 200 μm

**CBCT upper jaw**

The X-ray image shows the upper jaw.
Resolution: 200 μm

**CBCT lower jaw**

The X-ray image shows the lower jaw.
Resolution: 200 μm

**R****CBCT 5x5 Maxilla Molar right**

The X-ray image depicts the right molar region of the maxilla with a volume of 5x5 cm.
Resolution*: 120 μm

**R****CBCT 5x5 Maxilla Premolar right**

The X-ray image depicts the right premolar region of the maxilla with a volume of 5x5 cm.
Resolution*: 120 μm

**CBCT 5x5 Maxilla Front**

The X-ray image depicts the front region of the maxilla with a volume of 5x5 cm.
Resolution*: 120 μm

**L****CBCT 5x5 Maxilla Premolar left**

The X-ray image depicts the left premolar region of the maxilla with a volume of 5x5 cm.
Resolution*: 120 μm

**L****CBCT 5x5 Maxilla Molar left**

The X-ray image depicts the left molar region of the maxilla with a volume of 5x5 cm.
Resolution*: 120 μm

**R****CBCT 5x5 Mandible Molar right**

The X-ray image depicts the right molar region of the mandible with a volume of 5x5 cm.
Resolution*: 120 μm

**R****CBCT 5x5 Mandible Premolar right**

The X-ray image depicts the right premolar region of the mandible with a volume of 5x5 cm.
Resolution*: 120 μm

**CBCT 5x5 Mandible Front**

The X-ray image depicts the front region of the mandible with a volume of 5x5 cm.
Resolution*: 120 μm

**L****CBCT 5x5 Mandible Premolar left**

The X-ray image depicts the left premolar region of the mandible with a volume of 5x5 cm.
Resolution*: 120 μm

CBCT images



CBCT 5x5 Mandible Molar left

The X-ray image depicts the left molar region of the mandible with a volume of 5x5 cm.

Resolution*: 120 μm

* The resolution can be changed to 80 μm in the service menu of the unit.

For panoramic images of children, the size of the radiation field is reduced with the aid of an additional collimator. The radiation dose is significantly reduced for this image.

Panoramic images



Standard

The standard panoramic image records the complete dental area with ascending dental branches and maxillary joints.



Front

The image shows a reduced dental area without ascending dental branches.

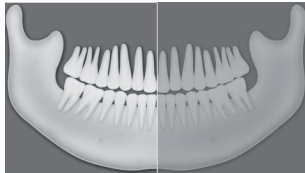

Right

The image only shows the right dental area.

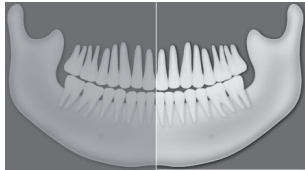

Left

The image only shows the left dental area.



Orthogonal

The image shows the complete dental area and is generated perpendicular to the maxillary arch. This prevents overlapping crowns.

Panoramic images

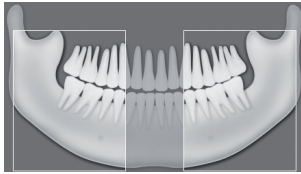

Bitewing

The image shows the lateral dental area with a size limited to the bite wings.

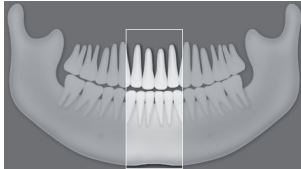

Bite wing front

The image shows the anterior area with a size limited to the bite wings.

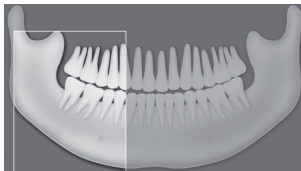

Bite wing right

The image shows the right posterior region with a size limited to the bite wings.

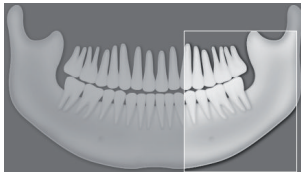

Bite wing left

The image shows the left posterior region with a size limited to the bite wings.

Temporomandibular imaging



Maxillary joint, lateral

The image shows the lateral maxillary joints with an open and closed mouth in 4-fold depiction on one image.



Maxillary joint, PA

The image shows the posterior-anterior maxillary joints with an open and closed mouth in 4-fold depiction on one image.

Sinus images

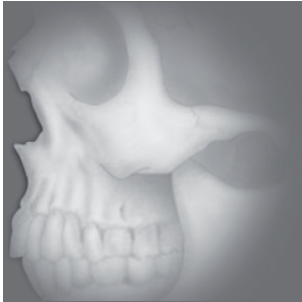

Sinus, lateral

The image shows the lateral sinuses.



Sinus, PA

The image shows the posterior-anterior sinuses.

Cephalometric exposures



Head lateral full format

The X-ray image shows the patient's complete skull from the side.

This X-ray program can be selected dependent on the version.



Head lateral

The X-ray image shows the patient's cranium from the side.

This X-ray program can be selected dependent on the version.

Cephalometric exposures**Head PA**

The image shows the posterior/anterior cranium. It is suitable for semi-axial cranial images and provides a cranial eccentric overview.

**SMV**

The image shows the cranium in a submentoververtex projection. It is suitable for recording the maxillary arch and the maxillary joints, for example.

**Waters View**

This view is suitable for recording the articular head in the mandibular joint socket, for example.

**Carpus**

The image shows the carpus of the patient. It is suitable for providing conclusions on the growth stage of the body/jaw.

7.3 Panoramic X-ray unit

For the X-ray image, the patient is positioned in the unit using the corresponding positioning aids and then accurately aligned using the positioning beams.



WARNING

Danger due to non-processed products

Risk of infection for operator and patient

- › Reprocess the product correctly and sterilise it as required prior to first use and after every subsequent use.
- › Do not reprocess disposable items.

Inserting the head supports

If no head supports are inserted or if they are dirty, insert new head supports before positioning the patient.

- › Remove any dirty head supports by pulling them out.
 - › Insert new head supports.
- When doing this, make sure that the cushions of the head supports face inwards.

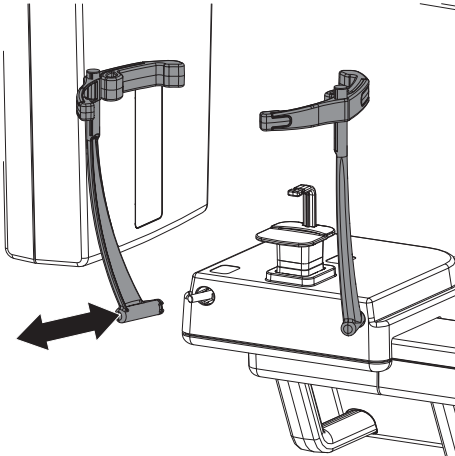

Inserting the cushions of the head supports

If no cushions are inserted in the head supports or if they are dirty, insert new cushions before positioning the patient.

- › Remove any dirty cushions by pulling them out.

- › Inserting the cushion holder.



- › Insert new cushions in the cutout provided on the head supports.

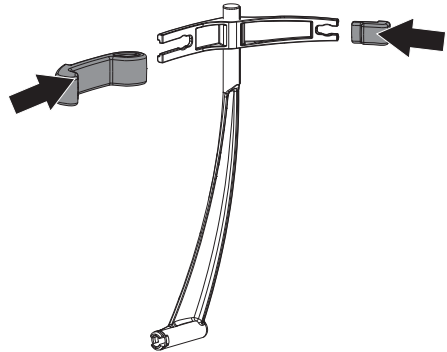

Inserting the positioning aid for CBCT images

We recommend using the mounting for the bite block on CBCT images. When using the bite

block holder, the bite block or the comfort bite block with foam support can optionally be used. On edentulous patients the chin support for edentulous patients can be used.

The other positioning aids can be used depending on the application scenario.

› Insert the holder for the bite block.

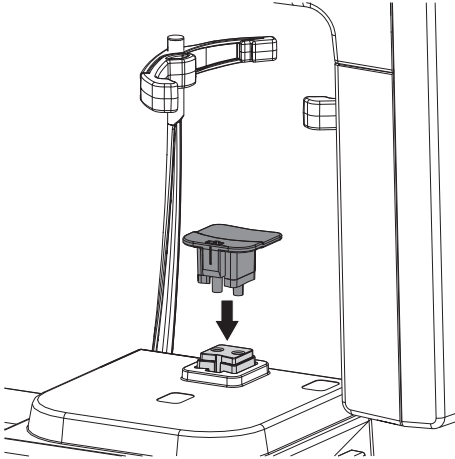

The bite block can be used with or without a hygienic protective cover.

We recommend using the bite block with a hygienic protective cover.

If the bite block is used without a hygienic protective cover, refer to the instructions under "7.3 Panoramic X-ray unit" and the reprocessing instructions under "9 Reprocessing".



If you are using the comfort bite block with foam support, refer to the instructions under "7.3 Panoramic X-ray unit" and observe the preparation under "9 Reprocessing".



WARNING

There is a danger of cross contamination if hygienic protective covers are not used or they are used more than once.

- › Reprocess the bite block without the hygienic protective cover after use.
- › Do not use the hygienic protective cover more than once (disposable item).



WARNING

Danger of cross contamination when not using the foam support or when using the foam support more than once

- › Reprocess the comfort bite block without the foam support after use.
- › Do not use the foam support more than once (disposable item).



WARNING

Danger due to re-use of products intended for single use

- The disposable item is damaged after use and cannot be reused.
- › Dispose of disposable items after use.

- › Use either the bite block or the comfort bite block with foam support.

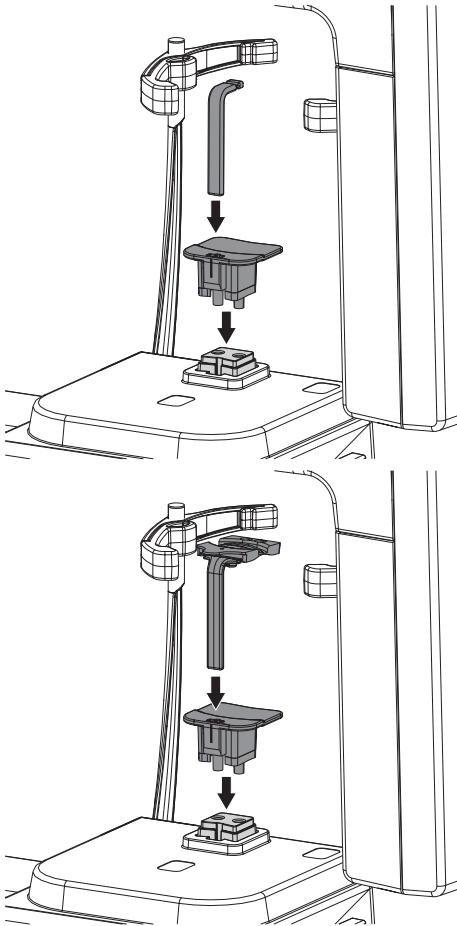

› On edentulous patients the chin support for edentulous patients can be used.

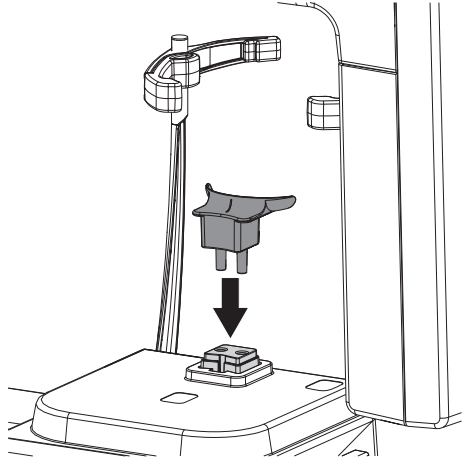

Inserting the positioning aid for panoramic images

When taking panoramic images, we recommend using the holder for bite block and the bite block or comfort bite block with foam support. On edentulous patients the chin support for edentulous patients can be used. The other positioning aids can be used depending on the application scenario.

i The bite block can be used with or without a hygienic protective cover. We recommend using the bite block with a hygienic protective cover. If the bite block is used without a hygienic protective cover, refer to the instructions under "Inserting the positioning aid for panoramic images with hygienic protective cover (optional)" and observe the preparation under "9 Reprocessing".

i If you are using the comfort bite block with foam support, refer to the instructions under "Inserting the positioning aid for panoramic images" and observe the preparation under "9 Reprocessing".

**WARNING**

There is a danger of cross contamination if hygienic protective covers are not used or they are used more than once.

- › Reprocess the bite block without the hygienic protective cover after use.
- › Do not use the hygienic protective cover more than once (disposable item).

**WARNING**

Danger of cross contamination when not using the foam support or when using the foam support more than once.

- › Reprocess the comfort bite block without the foam support after use.
- › Do not use the foam support more than once (disposable item).

- › Insert the bite block holder and the bite block or comfort bite block with foam support.

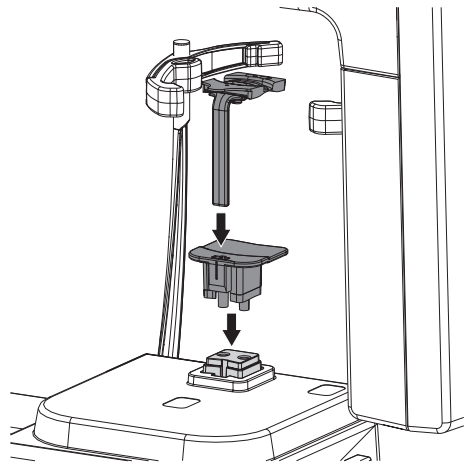
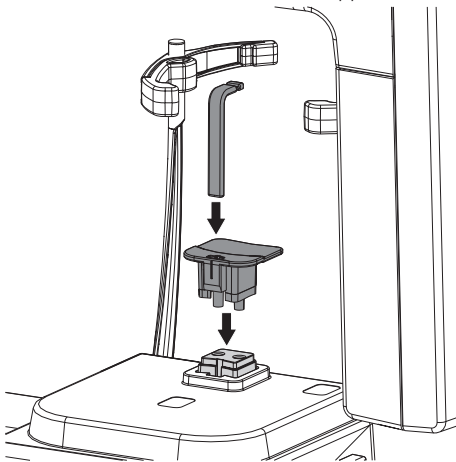

- › On edentulous patients the chin support for edentulous patients can be used.

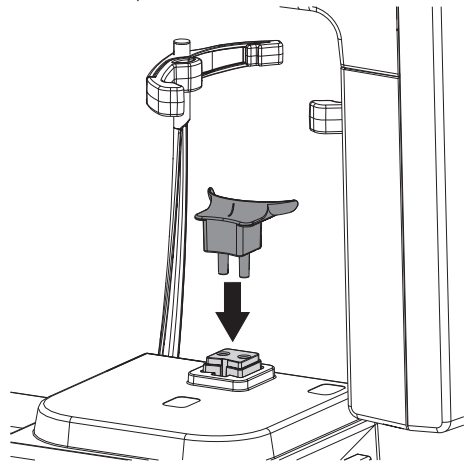

Inserting the positioning aid for panoramic images with hygienic protective cover (optional)



WARNING

Risk of cross contamination due to non-reprocessed bite block

› Reprocess the bite block in accordance with the reprocessing instructions.

› Optionally place a hygienic protective cover over the bite block.

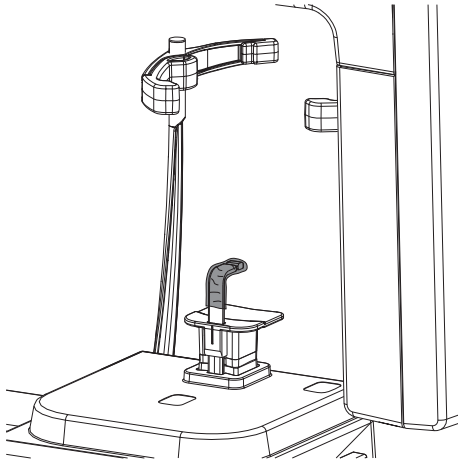

Inserting the positioning aid for the maxillary joint image

Correct image acquisition is only possible with the chin support for maxillary joint images.

› Insert the chin support for the maxillary joint image.

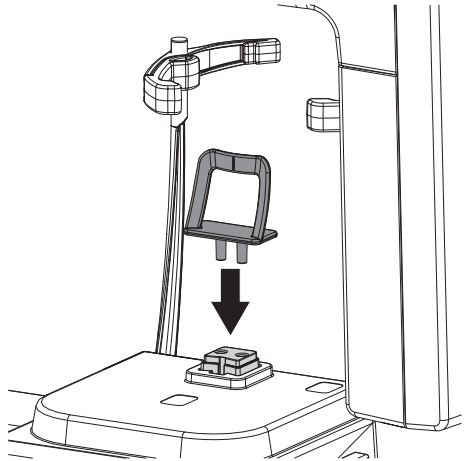

Inserting the positioning aid for sinus images

› Insert the chin support for sinus images.

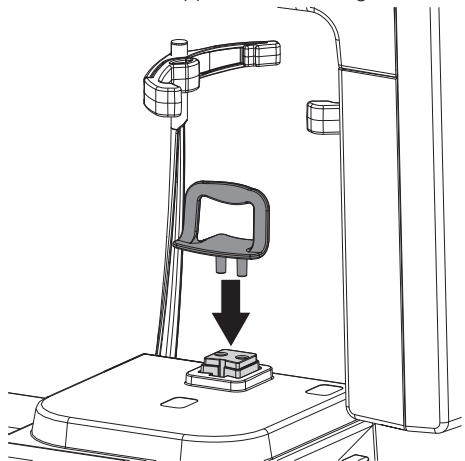

Opening the head supports

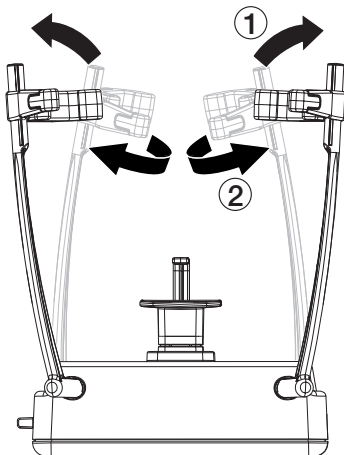

- › Open the head supports by pressing the "Close/open head supports" button on the touch screen.
- › Open the cushion holder with cushions properly such that the patient can be positioned.

7.4 Positioning the patient

For the X-ray image, the patient is accurately aligned using the positioning beams.

Requirements:

- ✓ The patient has taken off jewellery and metal objects, e.g. earrings, hair slides, glasses, artificial dentures or orthodontic aids.
- ✓ The patient has put on a protective lead apron.
- ✓ The patient has been informed about the X-ray procedure.
- ✓ The patient has been informed that the unit may pass by close to his/her head (including through the field of vision). If patients feel uncomfortable with this, they can close their eyes while the image is being taken.
- ✓ The patient has been informed that he/she can press the emergency stop switch in the event of anxiety during image acquisition.
- ✓ The patient has been informed that he has to place his tongue against the roof of his mouth during the X-ray.
- ✓ The patient has been informed that he has to keep his eyes closed during positioning of the X-ray positioning beam.
- ✓ The patient has been told not to move while the X-ray image is being taken until the unit is back in the starting position.



CAUTION

Danger of injury due to movement of the C-shaped angle connector piece

After switching on the unit and confirming the parameters on the touch screen, the C-shaped angle connector piece is positioned. Persons can be injured during this.

- › Nobody must remain in the area of the C-shaped angle connector piece while the unit is being switched on.

- › Bring the patient into an upright position at the unit.

It is also possible to position patients in a seated position (e.g. wheelchair users, tall patients).

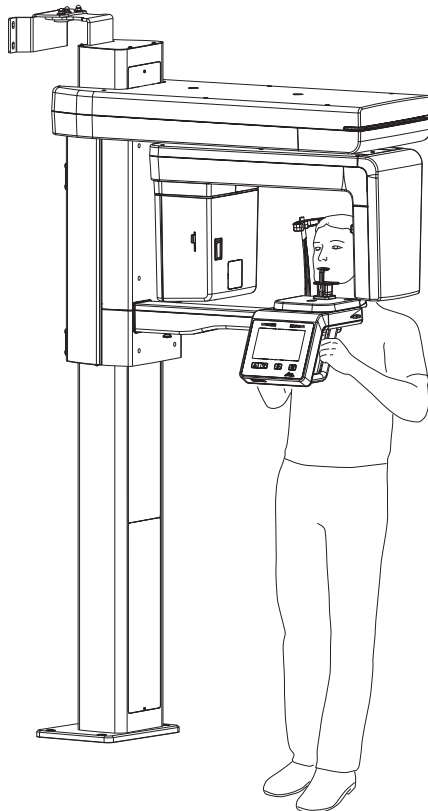

- › Use the   buttons to set the height of the unit.

CBCT image acquisition

The patient is positioned as follows depending on the indication:

- › The patient bites onto the bite block, with the upper and lower incisors resting in the grooves provided.

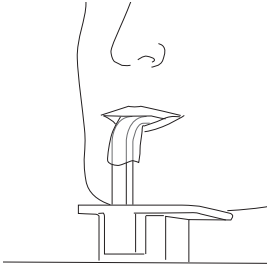

- › Use of the chin support for edentulous patients. Here, the patient places his/her chin on the chin support.

Panoramic image

- › The patient bites onto the bite block, with the upper and lower incisors resting in the grooves provided.

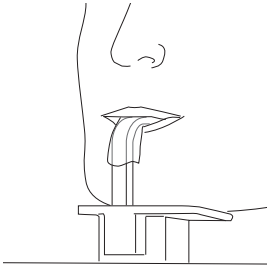

- › Use the chin support for edentulous patients in the case of patients who do not have any teeth. Here, the patient places his/her chin on the chin support.

Maxillary joint image

- › Position the patient with the upper lip against the chin support.

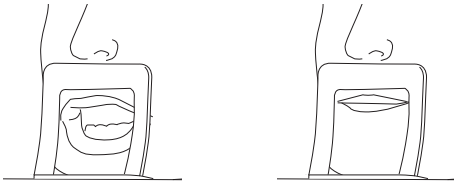

Sinus image

- › Position the patient so that their bottom lip presses lightly against the chin support.

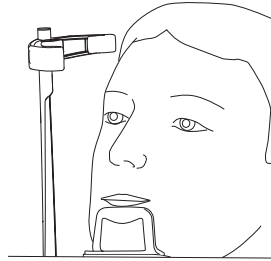

Adjusting the position with the positioning beams

- i** The beam localisers use class 1 laser beams. Although these can dazzle the patient, they are safe and will not damage the eye.

- i** For CBCT images it is sufficient to perform positioning base on the mid-sagittal plane.

For all other image types the patient needs to be positioned more accurately with the aid of the following steps.

The alignment of the upper canine beam localiser is crucial for the quality of panoramic images.

- › Check to make sure that the patient has closed his/her eyes.
- › If necessary, correct the height of the unit again.
- › Activate the beam localisers with the  button.

- › Check the beam localiser for the mid-sagittal plane and correct the position of the patient if necessary.

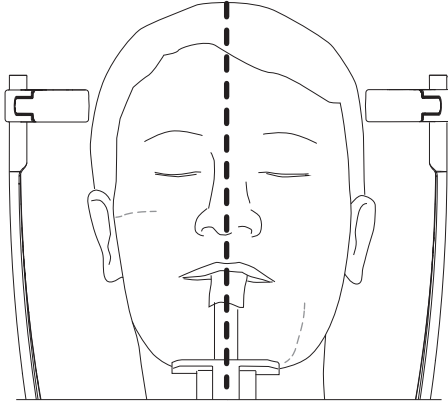

- › Align the head of the patient according to the Frankfurt plane with the aid of the beam localiser.

Exception: sinus image. Patient over-extends the cervical vertebral column to the rear by approx. 10° to 15°.

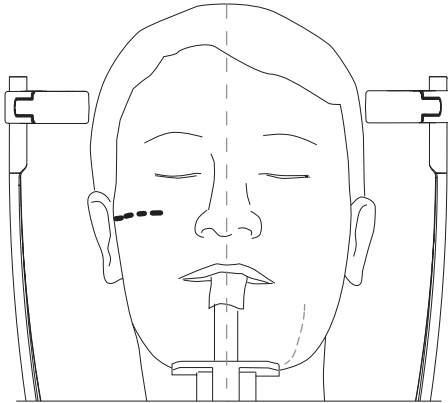
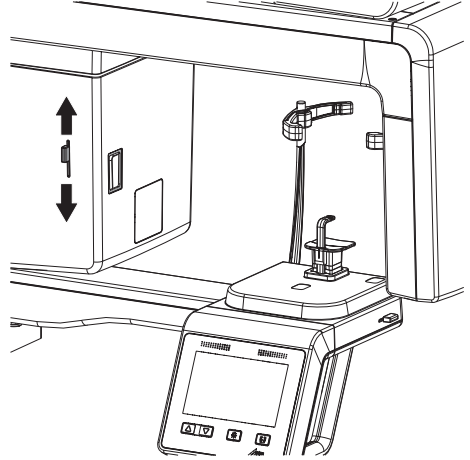
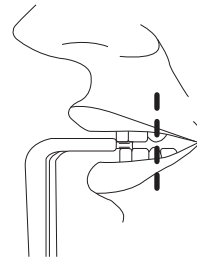

Fig. 3: Frankfurt plane: laser height to the lower edge of the eyes

- › Correct any inclination of the head via the height of the unit. If necessary, correct the beam localiser manually.



- › Direct the upper canine beam localiser as precisely as possible to the middle of the upper canine. Have the patient smile so the upper canine is visible.



- › If necessary, correct the beam localiser manually.

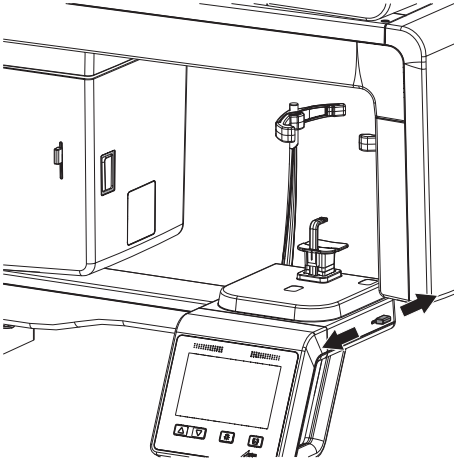

- › Once the patient has been correctly positioned using the beam localisers, deactivate the beam localisers using the  button.

Adjusting the head supports

- › Adjust the height of the head supports.

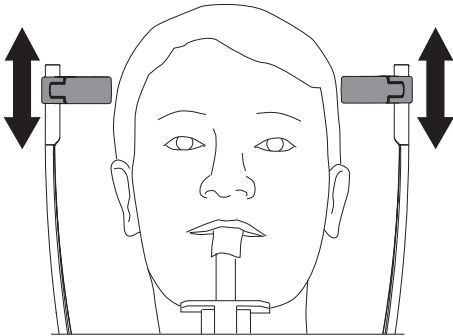

- › Carefully press the head supports by hand towards the head in order to check that they are in the right position. The device or the head supports are not damaged in the process. Ideally, the head supports should make contact slightly above the eye brows; correct the position as required.

- › Close the head supports with the  button. To do this, just press the button briefly – don't press and hold.

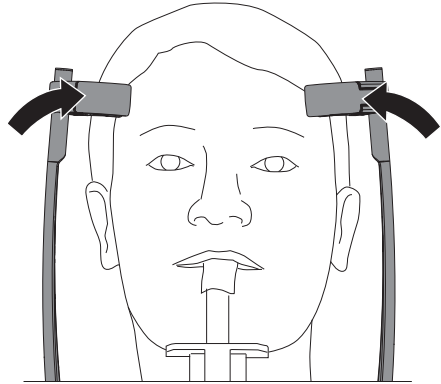

The head supports automatically close against the head of the patient with a defined pressure.

7.5 Cephalometric exposures

Setting up the unit

- › Disinfect the positioning aids, see "8 Cleaning and disinfection".
- › Fit the ear rods with protective caps and the nose support with a protective cover.

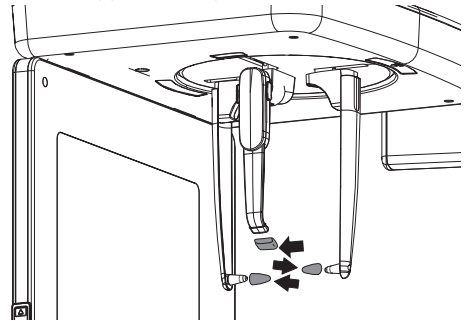

- › Grasp the holder for the ear rods at the top and push outwards.

- › Swivel the nose support to the side.

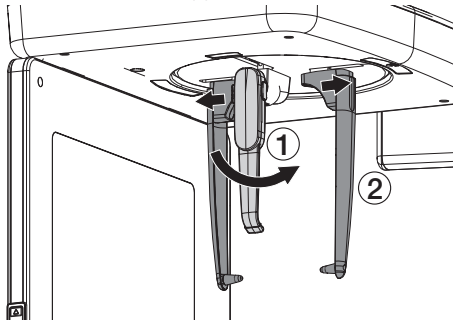



- › Use the   buttons to set the unit to the height of the patient.

Positioning the patient

For the X-ray image, the patient is positioned in the unit using the relevant positioning aids. The patient must not move while the image is being taken.

Requirements:

- ✓ The patient has taken off jewellery and metal objects, e.g. earrings, hair slides, glasses, artificial dentures or orthodontic aids.
- ✓ The patient has put on a protective lead apron.
- ✓ The patient has been informed about the X-ray procedure.
- ✓ The patient has been told not to move while the X-ray image is being taken until the unit is back in the starting position.
- › Use the   buttons to set the unit to the height of the patient.

Preparations for the head PA image

- ✓ The holders for the ear rods are pushed apart.
- ✓ The nose support is swivelled upwards.
- ✓ The holders for the ear rods are rotated by 90° to the sensor.
- ✓ The ear rods are fitted with protective caps and the nose support is fitted with a protective cover.
- ✓ The unit is adjusted to the height of the patient
- › Place the patient vertical with his/her face towards the sensor. The Frankfurt plane of the patient is parallel to the floor.

- › Adjust the holders for the ear rods to the height of the external auditory canals of the patient.

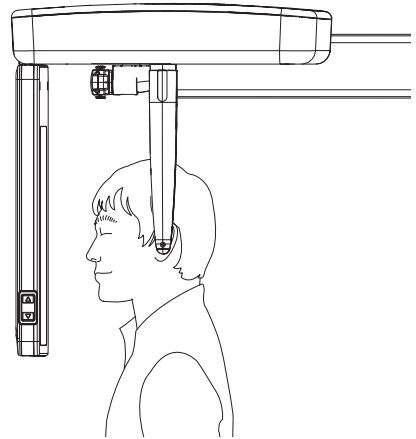

Preparations for the lateral head image

- ✓ The holders for the ear rods are pushed apart.
- ✓ The nose support is swivelled upwards.
- ✓ The holders for the ear rods are in a line with the sensor.
- ✓ The ear rods are fitted with protective caps and the nose support is fitted with a protective cover.
- ✓ The unit is adjusted to the height of the patient
- › Place the patient with his/her face towards the nose support. The Frankfurt plane of the patient is parallel to the floor.



WARNING

Risk of injury when positioning the ear rods

If the ear rods are positioned with jerky movements on the patient, there is a risk that the patient's eardrum will be damaged.

- › Grasp the ear rod holder at the top with both hands and gently squeeze it together until it is placed in the patient's auditory canal.
- › Adjust the holders for the ear rods to the height of the external auditory canals of the patient.



CAUTION

Danger of injury due to nose support not being positioned.

The moving secondary collimator causes injury and damage to the machine if the nose support is folded to the side.

› Correctly position the nose support.

› Position the nose support at the height of the nasal bridge.

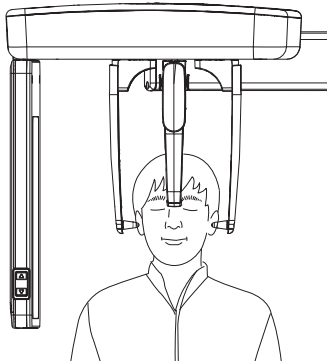

Preparations for the SMV image

- ✓ The holders for the ear rods are pushed apart.
- ✓ The nose support is swivelled upwards.
- ✓ The holders for the ear rods are rotated by 90° to the sensor.
- ✓ The ear rods are fitted with protective caps.
- ✓ The unit is adjusted to the height of the patient
- › Place the patient upright, with his/her face towards the secondary collimator.
- › Instruct the patient to tilt their head backwards.

› Adjust the holders for the ear rods to the height of the external auditory canals of the patient.

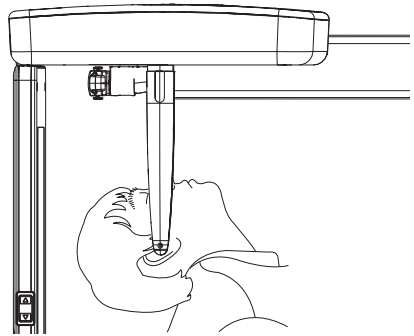

Preparations for the Waters View image

- ✓ The holders for the ear rods are pushed apart.
- ✓ The nose support is swivelled upwards.
- ✓ The holders for the ear rods are rotated by 90° to the sensor.
- ✓ The ear rods are fitted with protective caps.
- ✓ The unit is adjusted to the height of the patient
- › Place the patient vertical with his/her face towards the sensor.
- › Instruct the patient to tilt their head backwards.
- › Adjust the holders for the ear rods to the height of the external auditory canals of the patient.

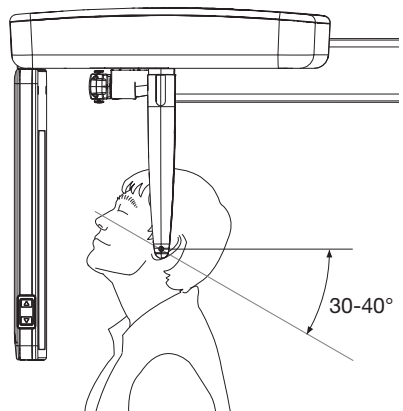

Preparations for the carpus image

- ✓ The holders for the ear rods are pushed apart.
- ✓ The holders for the ear rods are rotated by 90° to the sensor.
- › Insert the carpus plate into the holes provided until it clicks into place.

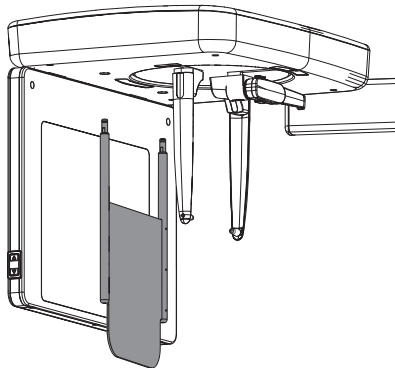

- › Place the patient sideways to the unit.
- › Adjust the height of the unit so the patient can lay his/her hand on the carpus plate with the arm bent.
- › The patient lays his/her right hand on the carpus plate with the fingers outstretched.

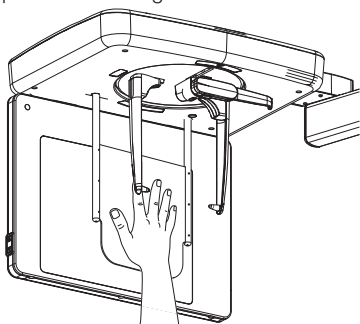

7.6 Start a test run

The test run ensures that the unit can perform the image acquisition without any problems. This prevents unnecessary exposure of the patient to radiation.



No radiation is generated during the test run.

Requirements:

- ✓ The patient is correctly positioned in the unit using the positioning aids and the positioning beams.
- ✓ The required imaging program has been selected.
- › Touch **Test run** on the touch screen.
- › Touch **Run** and hold.
While doing this, constantly monitor the movements of the unit. If the unit is obstructed in its movements, let go of the **Run** button. The unit will stop immediately. Reposition the patient.
- › Press **Return run** to perform the return run.

7.7 Taking the X-ray image



CAUTION

Injuries through x-rays

- X-rays can cause tissue damage.
- › Comply with the radiation protection regulations.
- › Maintain the minimum distance.



CAUTION

Danger of excessively high radiation dose

- › Before an image acquisition is triggered, all data entered on the PC must be checked on the touch screen.
- › Check all parameters on the touch screen and change them if necessary.
The changed parameters are immediately synchronised with the imaging software. The parameters can then no longer be changed in the imaging software.
- › Remind the patient to press his/her tongue against the gums during image acquisition.

- › Press **Start** to confirm the parameters. The C-shaped arm is positioned. The LED on the exposure switch and the status LED on the unit light up green. The touch screen displays that the unit is ready to take an image.

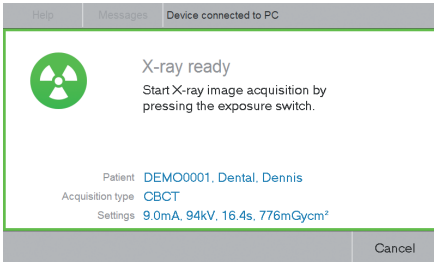

- › Trigger the image by pressing and holding the button on the exposure switch until the acoustic signal stops and the control lamp goes out. The scan times depend on the patient type, imaging program and image quality (see "12 Program parameters"). Image acquisition is started. While the image is being taken, the LED on the exposure switch and on the unit lights up yellow. An acoustic signal sounds.

 If the button on the exposure switch is released before the control lamp goes out or the emergency stop switch is pressed (e.g. if there is a danger to the patient or to anyone else in the area) then the ongoing image acquisition will stop. The X-ray image will be unusable as a result and should be retaken as required. In this case the operator must use their skills and training to decide on the risks of a repeated image acquisition. In addition, an error message appears on the touch screen.

While an X-ray is being taken, this is indicated on the touch screen with:

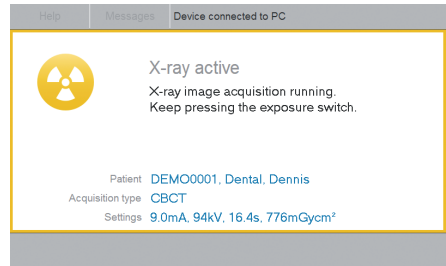

-  On maxillary joint images, it is then necessary to acknowledge a message on the touch screen and trigger a second image acquisition. The images are then combined into a single image.

The LED on the unit lights up blue when the X-ray acquisition has been completed. The C-shaped arm does not automatically move back to the starting position after the trigger button is released.

- › Click **OK** to confirm the message.

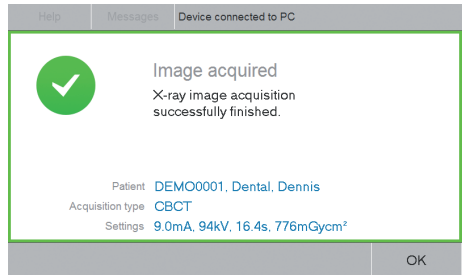

- › Release the head support. The patient can leave the X-ray room.
- › Remove the hygienic protective cover.
- › Remove and disinfect the positioning aids.
- › The unit can be positioned back in its start position by touching **Start position**. Otherwise, the C-shaped arm is positioned via the imaging software when adjusting the parameters.

7.8 Emergency stop switch

The emergency stop switch stops the unit and switches it off. It can be used if the unit is taking an X-ray even though the exposure switch is no longer being pressed, or if the patient is injured or

the unit is damaged. It can also be used to avert an unwanted collision.

The yellow labels with the symbol  show the location of the emergency stop switch.

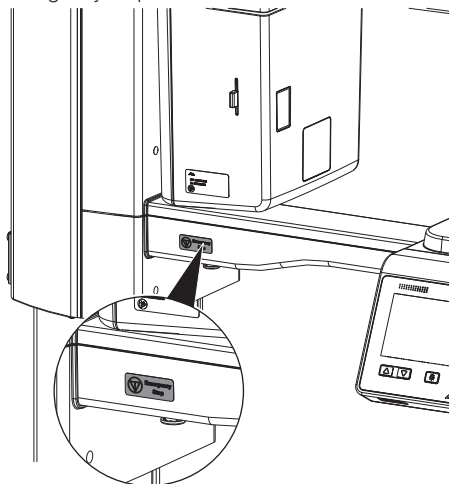

Fig. 4: Emergency stop switch label on the operator side

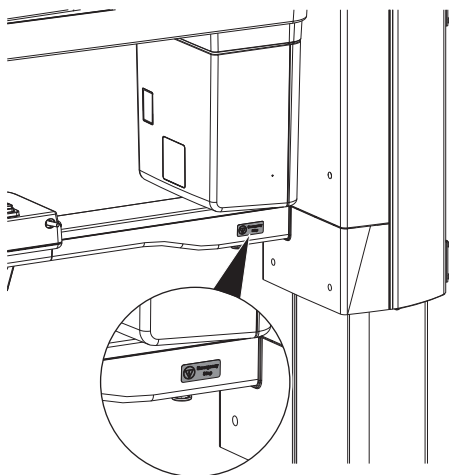

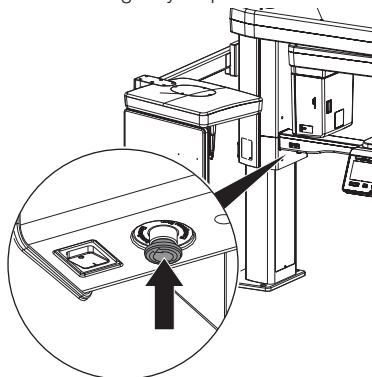

Fig. 5: Emergency stop switch label on the patient side

 Misuse of the emergency stop switch can lead to data loss.

› Press the emergency stop switch.



Device is switched off.

Releasing the emergency stop switch



CAUTION

Danger of injury due to movement of the C-shaped angle connector piece

After switching on the unit and confirming the parameters on the touch screen, the C-shaped angle connector piece is positioned. Persons can be injured during this.

› Nobody must remain in the area of the C-shaped angle connector piece while the unit is being switched on.

› Twist the emergency stop switch to release it.

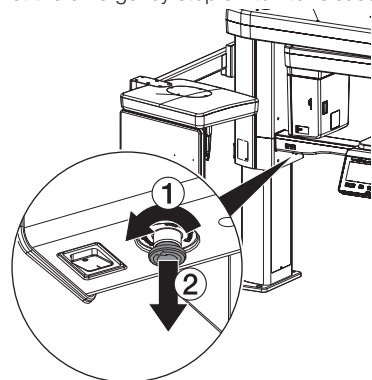

The unit will automatically restart.

8 Cleaning and disinfection



NOTICE

The use of unsuitable agents and methods can damage the unit and accessories.

Do not use any products based on phenolic compounds, halogen-releasing compounds, strong organic acids or oxygen-releasing compounds, as they may damage the materials.

- › Dürr Dental recommends using disinfectants from the Dürr Dental product range. Only the products specified in these instructions have been subjected to material compatibility testing by Dürr Dental.
- › Read the operating instructions for the disinfectants.



Wear protective gloves.



Prior to working on the unit or in case of danger, disconnect it from the mains.

8.1 Unit surfaces



NOTICE

Damage to the touch screen caused by cleaning it with disinfectant

- › Only clean the touch screen with a soft cloth and a commercially available cleaning agent.

The unit surface must be cleaned and disinfected of any contamination or soiling. Use the following cleaning agents and disinfectants:

- ✓ FD 322 quick-acting surface disinfectant
- ✓ FD 333 quick-acting surface disinfectant
- ✓ FD 350 disinfection wipes
- ✓ FD 366 quick-acting disinfectant for sensitive surfaces



NOTICE

Liquid can cause damage to the unit.

- › Do not spray the unit with cleaning and disinfectant agents.
- › Make sure that liquid does not get inside the unit.

- › Remove any soiling with a soft, damp, lint-free cloth.
- › Disinfect the surfaces using a disinfection wipe. Alternatively, use a quick-acting surface disinfectant on a soft, lint-free cloth. Comply with the operating instructions for the disinfectant when doing this.

8.2 Positioning aids

The positioning aids must be cleaned and disinfected if they are contaminated or soiled. Use the following cleaning agents and disinfectants:

- FD 322 quick-acting surface disinfectant
- FD 333 quick-acting surface disinfectant
- FD 350 disinfection wipes
- FD 366 quick-acting disinfectant for sensitive surfaces

Head support with cushion

- › Pull off the head supports from the unit.
- › Remove the cushions from the head supports.

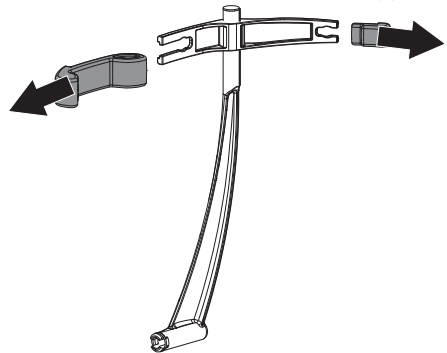

- › Remove the cushion holder.

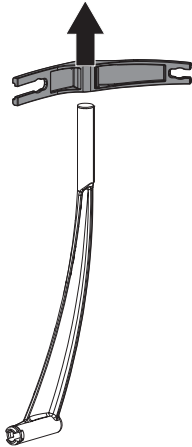

- › Remove any soiling with a soft, damp, lint-free cloth.
- › Disinfect the surfaces using a disinfection wipe. Alternatively, use a quick-acting surface disinfectant on a soft, lint-free cloth. Comply with the operating instructions for the disinfectant when doing this.
- › Reprocess the cushions (see "9 Reprocessing").

Ear rod holder with ear rods

- › Remove the ear rods from the ear rod holder.



- › Remove any soiling with a soft, damp, lint-free cloth.
- › Disinfect the surfaces using a disinfection wipe. Alternatively, use a quick-acting surface disinfectant on a soft, lint-free cloth. Comply with the operating instructions for the disinfectant when doing this.
- › Reprocess the ear rods (see "9 Reprocessing").

Nose support with protective cover

- › Remove the protective cover from the nose support.

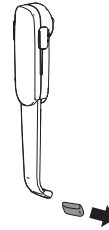

- › Remove any soiling with a soft, damp, lint-free cloth.
- › Disinfect the surfaces using a disinfection wipe. Alternatively, use a quick-acting surface disinfectant on a soft, lint-free cloth. Comply with the operating instructions for the disinfectant when doing this.
- › Reprocess the protective cover (see "9 Reprocessing").

Carpus plate and grips

- › Clean and disinfect the carpus plate and grips (see "8.1 Unit surfaces").

9 Reprocessing

The following accessories need to be reprocessed:

- Bite block:
 - Manual cleaning
 - Manual disinfection
 - Automatic cleaning and disinfection
 - Sterilisation
- Holder for bite block, chin support for mandibular joint image, chin support for edentulous jaws and chin support for sinus image
 - Manual cleaning
 - Manual disinfection
 - Automatic cleaning and disinfection
- Cushion for head supports Plus
 - Manual cleaning
 - Manual disinfection
 - Automatic cleaning and disinfection
- Ear rods and protective cover for nose support
 - Manual cleaning
 - Manual disinfection
 - Automatic cleaning and disinfection

In order to prevent damage to the accessories, only the methods described above must be used.

9.1 Risk analysis and categorisation

A risk analysis and categorisation of medical products often used in dentistry must be performed before their reprocessing by the operator. Comply with all national directives, standards and specifications such as e. g. the "Recommendations from the Commission for Hospital Hygiene and Infection Prevention".

Accessories of the medical device are also subject to reprocessing.

Recommended classification for bite block

Recommended classification given proper use of the bite block:

Semi-critical

Recommended classification for other accessories

Recommended classification given proper use of the holder for bite block, chin support for mandibular joint image, chin support for edentulous jaws, chin support for sinus image, cushions for head supports Plus, ear rods and protective cover for nose support:

Non-critical

The operator is responsible for correct classification of the medical products, defining the reprocessing steps and performing the reprocessing.

9.2 Preparation process in accordance with ISO 17664

Carry out the procedure for reprocessing after every treatment in accordance with the preparation process set out in ISO 17664.



Important information!

The reprocessing notes in accordance with ISO 17664 have been independently tested by Dürr Dental for the preparation of the device and its components for their reuse.

The person conducting the reprocessing is responsible for ensuring the reprocessing performed using the equipment, materials and personnel achieves the desired results. This requires validation and routine monitoring of the reprocessing process. Any deviation from the instructions described herein by the staff preparing the equipment could lead to lower effectiveness and possible negative consequences: these lie solely with the staff responsible.

Frequent reprocessing has little effect on the device components. The end of the product life cycle is especially influenced by the amount of wear and tear or damage resulting from its use.

The use of soiled, contaminated and damaged components is at the sole responsibility of the person performing the reprocessing and the operator.

The reprocessing procedure was validated as follows:

- Pre-cleaning:
 - FD 350 disinfection wipes (Dürr Dental)
 - Cleaning brush
- Manual cleaning:
 - ID 215 enzymatic instrument cleaner (Dürr Dental)
- Manual disinfection:
 - ID 212 instrument disinfection (Dürr Dental)
- Automated cleaning and disinfection was performed in accordance with EN ISO 15883 with tested efficacy:
 - Washer-disinfector PG 8535 (Miele, Gütersloh, Germany)
 - Cleaning agent: Neodisher MediClean Forte
 - Programmes: *Cleaning without neutralisation* and *THERMAL DES*
- Steam sterilisation:
 - Steam steriliser Systec DX-45 (Systec GmbH, Linden, Germany)

9.3 General information

- › Comply with all national directives, standards and specifications for the cleaning, disinfection and sterilisation of medical products as well as the specific specifications for dental practices and clinics.
- › Comply with the specifications (see "9.5 Manual cleaning, intermediate rinsing, disinfection, final rinse, drying" and "9.6 Automatic cleaning, intermediate rinsing, disinfection, final rinse, drying") when selecting the cleaning and disinfectant agents to be used.
- › Comply with the concentration, temperature, residence time and post-rinsing specifications issued by the manufacturer of the cleaning and disinfectant agent.
- › Only use cleaning agents that are non-fixing and aldehyde-free and display material compatibility with the product.
- › Only use disinfectants that are aldehyde-free and display material compatibility with the product.
- › Do not use any rinse aid (danger of toxic residue on the components).
- › Only use freshly-produced solutions.
- › Only use distilled or deionised water with a low bacterial count (at least drinking water quality) that is free from facultatively pathogenic microorganisms (e.g. legionella bacteria).

- › Use clean, dry, oil and particle-free compressed air.
- › Do not exceed temperatures of 138 °C.
- › Subject all devices used (ultrasonic bath, cleaning and disinfection device (CD), sealing device, steam steriliser) to regular maintenance and inspections.

9.4 Preparation at the operating location



Wear protective gloves.



Wear protective goggles.



Use a mask.



Use protective clothing.



WARNING

Risk of infection from contaminated products

Danger of cross contamination

- › Reprocess the product correctly and promptly before its first use and after every subsequent use.
- › Protect the unit from contamination when transporting it from the treatment chair to the reprocessing location.
- › Brush off all surfaces below the water surface with a soft hygienic brush until they are clean to the eye.
- › Wipe off all surfaces for at least one minute with a disinfection wipe.

9.5 Manual cleaning, intermediate rinsing, disinfection, final rinse, drying

A combined cleaning and disinfectant agent is required for manual cleaning and disinfection. It must have the following properties:

- certified, possibly virucidal efficacy (DWW/RKI, VAH or European Standards)
- without chlorine, without solvent, no strong alkaline solutions (pH > 11), no strong oxidising agents

For further information, see: "8 Cleaning and disinfection".

Cleaning

- › Place individual parts in a cleaning agent bath making sure that all parts are covered.
- › Note the exposure times of the cleaning agent.

Intermediate rinsing

After the action time prescribed by the manufacturer:

- › Rinse off all components under water for at least 1 minute (temperature < 35°C).

Disinfection

- › Place individual components in a cleaning and disinfectant bath so that all parts are covered.
- › Note the action time for the disinfectant.

Final rinse

After the action time prescribed by the manufacturer:

- › Rinse off all components under water for at least 1 minute (temperature < 35°C).

Drying

- › If necessary, re-dry at a clean location using a hygienic, lint-free cloth.
- › Blow dry the components with compressed air in a clean location.

9.6 Automatic cleaning, intermediate rinsing, disinfection, final rinse, drying

Selection of the washer-disinfector

Automatic cleaning and disinfection requires a washer-disinfector with the following properties and validated processes:

- Corresponds to and tested in accordance with ISO 15883
- Certified program for thermal disinfection (A_0 value ≥ 3000 or at least 5 minutes at 93°C)
- Programme is suitable for the components and provides sufficient rinsing cycles.
For more information: "9.3 General information".

Selection of the cleaning agent automatic

The following properties are required:

- Material compatibility with the product
- Corresponds with the manufacturer's specifications of the CD

For further information, see: "9.3 General information".

Cleaning and disinfection

- › Place all components in the cleaning and disinfection unit (follow the manufacturer's instructions).
- › Make sure there are no hidden areas that are missed by the rinsing process.
- › Secure the components with a suitable fixture of the cleaning and disinfection unit.

9.7 Check for function

- › After the end of the cleaning and disinfection cycle, check the components for any residual soiling and residual moisture. If necessary, repeat the cycle.
- › If necessary, replace any damaged parts.
- › The components should be packaged as soon as possible after drying and checking.

9.8 Steam sterilising

Packing

For packaging of the components, only use transparent paper film sterilisation packaging that is approved for use in steam sterilisation according to the manufacturer's instructions. This includes:

- Temperature resistance up to 138°C
- Standards ISO 11607-1 and -2
- The applicable sections of the standard series EN 868

The sterilisation packaging must be sufficiently large. Once it is loaded, the sterilisation packaging may not be under any strain.

Steam sterilising



WARNING

Incorrect sterilisation reduces effectiveness and can damage the product.

- › Only steam sterilisation is permitted.
- › Comply with the specified process parameters.
- › Comply with the manufacturer's instructions regarding use of the steam steriliser.
- › Do not use any other methods.

Requirements placed on the steam steriliser:

- Corresponds to EN 13060 or EN 285 and/or ANSI AAMI ST79
- Suitable programme for the products listed (e. g. with hollow bodies, fractionated vacuum procedure in three vacuum steps)
- Sufficient product drying
- Validated process in accordance with ISO 17665 (valid IQ/OQ and product-specific performance appraisal (PQ))

Perform the following steps:

- › Sterilise the parts for sterilisation (at least 20 minutes at 121°C, at least 4 minutes at 270°F or at least 5 minutes at 134°C).



Do not exceed 138°C.

Marking

- › Mark the packaged, treated medical product in such a way as to ensure safe application.

9.9 Issue clearance for the parts for sterilisation

The reprocessing of the medical products ends with the documented clearance for storage and renewed use.

- › Document the clearance of the medical product after reprocessing.

9.10 Storing parts for sterilisation

- › Comply with the stated storage conditions:
 - Store the parts protected against contamination
 - Dust-protected, e.g. in a locked cabinet
 - Protected against moisture
 - Protected against excessive temperature fluctuations
 - Protected against damage

Packaging for a sterile medical device can suffer damage as a result of a particular incident and the passage of time.

Potential external contamination of the sterile barrier system should be taken into account in terms of aseptic preparation when establishing the storage conditions.

10 Maintenance

10.1 Recommended maintenance schedule



Only trained specialists or personnel trained by Dürr Dental may service the device.



Prior to working on the unit or in case of danger, disconnect it from the mains.



WARNING

Risk of infection from contaminated products

Danger of cross contamination

- › Reprocess the product correctly and promptly before its first use and after every subsequent use.



NOTICE

Damage to the X-ray tube due to overheating

- › Observe the cooling curves of the X-ray tube when working with the service tool.

Inspection interval

Inspection work

Every 3 years

- › Functional test of the display. Are all symbols displayed?
- › Functional test of the exposure button.
- › Do the various status LEDs light up?
- › Check that the head supports mechanism functions correctly. Are the head supports easy to detach and put back on?
- › Functional test of the emergency stop switch. Is the emergency stop switch easy to operate mechanically, and does it light up when pressed?
- › Visually check the beams localisers. Check the operation of the levers for adjusting the beam localisers.
- › Check the X-ray images for artefacts. If necessary, adjust the collimator and/or calibrate the sensor.
- › Check the firmware and software versions.
- › Perform a comparative dose measurement based on the requirements from the acceptance check (Germany, Switzerland and Austria only).
- › Recurring tests and tests after repairs to medical electrical equipment – IEC 62353 (VDE 0751-1).

Maintenance interval

Maintenance work

Every 3 years

- › Visually and acoustically check the linear movement on the C-shaped arm.
- › Check the operation of the lift motor. Does the unit lift and lower with minimal noise?

? Troubleshooting



CAUTION

Any oil leaking from the X-ray tube in the event of a fault is harmful.

- › Wipe up any oil immediately.
- › Do not swallow the oil.
- › Stop using the unit and inform a service technician.

11 Tips for operators and service technicians



Any repairs exceeding routine maintenance may only be carried out by qualified personnel or our service.

Error	Possible cause	Remedy
Unit does not switch on	EMERGENCY STOP SWITCH accidentally activated	› Release the EMERGENCY STOP SWITCH.
	No mains voltage	› Check the mains cable and electrical connection; replace if necessary. › Inform a Service Technician.
		› Check the mains fuse in the building.
	On/off switch is defective	› Inform a Service Technician.
Unit not responding	The unit has not yet completed the startup procedure	› After switching on, wait until the booting process has finished.
	Cables not correctly connected	› Check the cable connections.
	Plug-in contacts of the fibre optic cable are contaminated	› Clean plug-in contacts and sockets.
	Driver for PCI Express frame grabber card is not installed or incorrectly installed	› Install driver or complete Vis-taVox Plugin once again.
	COM port incorrectly configured	› Check the COM port in the service tool.

Error	Possible cause	Remedy
Error messages during start of an X-ray image or during shut down of the PC	Energy-saving options incorrectly configured	<ul style="list-style-type: none"> › Deactivate the energy-saving options in Windows and the BIOS completely.
	Supply voltage for graphic card inadequate or incorrectly connected	<ul style="list-style-type: none"> › Check the plug connections. › Compare requirements of the graphic card with the power supply of the PC, use larger power pack if necessary.
	PC and/or graphic card do not comply with the specified system requirements	<ul style="list-style-type: none"> › Set up system in accordance with the system requirements.
	User account control (UAC) has not been correctly configured	<ul style="list-style-type: none"> › Adjust user account control according to the information in the installation instructions.
	USB dongle not detected	<ul style="list-style-type: none"> › Check whether the USB dongle (included in scope of delivery) is plugged into the reconstruction computer, or check that the USB dongle is correctly plugged in.
	Virus scanner prevents the acquisition of an X-ray image	<ul style="list-style-type: none"> › Add the installation paths of the imaging software as exceptions in the virus scanner.
	Firmware of the unit does not match the software version	<ul style="list-style-type: none"> › Check software versions and update if necessary.
	The unit calibration has not been imported or incompletely imported	<ul style="list-style-type: none"> › Carry out initial commissioning using the service tool again/initially.
Door contact is not closed	<ul style="list-style-type: none"> › Check door contact and plug-in connections of the door contact, close door properly. 	

 Appendix

12 Program parameters

The extraoral dental X-ray system meets the requirements set out in standard IEC 60601-2-63. The dosage information complies with the requirements of the standard and is stated in mGy.



The accuracy of the DAP/dose values is $\pm 50\%$.

12.1 CBCT program parameters

CBCT image acquisition, normal image volume, 16.4 s								
	4.0 mA		6.3 mA		8.0 mA		10.0 mA	
	mGy	mGycm ²	mGy	mGycm ²	mGy	mGycm ²	mGy	mGycm ²
75 kV	4.00	215.92	6.13	331.05	7.79	420.70	9.74	526.41
79 kV	4.50	242.90	6.89	372.41	8.76	473.26	10.96	592.17
90 kV	6.00	324.11	9.20	496.93	11.69	631.50	14.63	790.18
94 kV	6.55	353.92	10.04	542.63	12.77	689.58	15.97	862.85

CBCT image acquisition, normal image volume 5x5, 11 s										
	4.0 mA		6.3 mA		8.0 mA		10.0 mA		11.0 mA	
	mGy	mGyc m ²	mGy	mGyc m ²	mGy	mGyc m ²	mGy	mGyc m ²	mGy	mGyc m ²
79 kV	3.02	118.85	4.63	182.22	5.88	231.56	7.36	289.75	8.08	318.22
94 kV	4.40	173.17	6.74	265.51	8.57	337.41	10.72	422.19	11.78	463.68
98 kV	4.77	187.76	7.31	287.87	9.29	365.83	11.63	457.75	12.77	502.73

CBCT image acquisition, upper jaw image volume, 16.4 s								
	4.0 mA		6.3 mA		8.0 mA		10.0 mA	
	mGy	mGycm ²	mGy	mGycm ²	mGy	mGycm ²	mGy	mGycm ²
75 kV	4.00	141.17	6.13	216.44	7.79	275.05	9.74	344.17
79 kV	4.50	158.81	6.89	243.48	8.76	309.42	10.96	387.17
90 kV	6.00	211.90	9.20	324.89	11.69	412.88	14.63	516.62
94 kV	6.55	231.39	10.05	354.77	12.77	450.85	15.97	564.13

CBCT image acquisition, lower jaw image volume, 16.4 s								
	4.0 mA		6.3 mA		8.0 mA		10.0 mA	
	mGy	mGycm ²	mGy	mGycm ²	mGy	mGycm ²	mGy	mGycm ²
75 kV	4.00	164.40	6.13	252.06	7.79	320.32	9.74	400.81
79 kV	4.50	184.94	6.89	283.56	8.76	360.34	10.96	450.89
90 kV	6.00	246.78	9.20	378.37	11.69	480.83	14.63	601.65
94 kV	6.55	269.48	10.05	413.16	12.77	525.05	15.97	656.98

12.2 Panoramic program parameters

Pano image acquisition, normal jaw arch, normal patient, quality HQ, 13.5 s

	4.0 mA		6.3 mA		10.0 mA	
	mGy	mGycm ²	mGy	mGycm ²	mGy	mGycm ²
60 kV	3.85	24.28	6.06	38.15	9.57	60.31
67 kV	4.74	29.84	7.43	46.83	11.76	74.09
70 kV	5.12	32.24	8.03	50.59	12.70	80.03
74 kV	5.66	35.66	8.88	55.95	14.05	88.52
80 kV	6.47	40.79	10.16	64.00	16.07	101.25

	12.5 mA		14.0 mA	
	mGy	mGycm ²	mGy	mGycm ²
60 kV	11.77	74.18	13.21	83.23
67 kV	14.46	91.07	16.22	102.21
70 kV	15.61	98.37	17.52	110.40
74 kV	17.27	108.81	19.38	122.11
80 kV	19.76	124.46	22.17	139.68

12.3 Programme parameters for cephalometric projections

The extraoral dental X-ray system meets the requirements set out in standard IEC 60601-2-63. The dosage information complies with the requirements of the standard and is stated in mGy.

Image quality	Program	Voltage	Current	DAP	Kerma	Scan time
		kV	mA	mGycm ²	mGy	s
SD	Head, lateral	90	14	21.73	0.34	1.9
SD	Head, full, lateral	90	14	54.33	0.86	3.9
SD	Head PA	90	14	26.47	0.42	2.4
SD	SMV	90	14	26.47	0.42	2.4
SD	Waters View	90	14	26.47	0.42	2.4
SD	Carpus	88	6.3	11.44	0.18	2.4

Image quality	Program	Voltage	Current	DAP	Kerma	Scan time
		kV	mA	mGycm ²	mGy	s
HD	Head, lateral	90	14	53.72	0.85	3.9
HD	Head, full, lateral	90	14	58.22	0.92	5.4
HD	Head PA	90	14	53.72	0.85	4.9
HD	SMV	90	14	53.72	0.85	4.9
HD	Waters View	90	14	53.72	0.85	4.9

Image quality	Program	Voltage	Current	DAP	Kerma	Scan time
		kV	mA	mGycm ²	mGy	s
HD	Carpus	88	6.3	22.85	0.36	4.9

13 Information on scattered radiation

R °	1 m mR/h	1.5 m mR/h	2 m mR/h
315	76.4	19.4	8.6

13.1 CBCT scattered radiation

Test equipment: Dosimeter Radcal 9015

Test conditions	
Program parameters	CBCT
Image acquisition volume	Normal
Voltage	99 kVp
Current	14 mA

R °	1 m mR/h	1.5 m mR/h	2 m mR/h
0	588.2	135.3	87.1
45	549.3	249.4	106.8
90	472.6	307.3	78.4
135	458.8	287.6	89.3
180	12.9	4.6	1.3
225	410.5	288.7	98.2
270	663.2	301.4	112.4
315	429.7	194.2	92.3

13.2 Pano scattered radiation

Test equipment: Dosimeter Radcal 9015

Test conditions	
Program parameters	Panoramic Standard
Patient size	Normal
Voltage	80 kVp
Current	14 mA

R °	1 m mR/h	1.5 m mR/h	2 m mR/h
0	60.9	17.7	8
45	19.6	12.4	5.8
90	10.6	6.8	4.1
135	22.1	12.5	5.6
180	1	0	0
225	45.4	21.4	9.4
270	47.6	21.9	9.2

14 Information on the leakage rate

Test equipment: Dosimeter Victoreen 660

Test conditions

Program parameters	HD / Adult, child / Standard Pano
Distance to the focal spot	1 m
Voltage	90 kVp
Current	16 mA

Direction °	HD, Adult, 13.5 s	HD, Child, 11.5 s
0	0 mR/h	1.5 mR/h
10	3.9 mR/h	3.7 mR/h
20	4 mR/h	4.5 mR/h
30	0 mR/h	4.8 mR/h
40	0 mR/h	0.9 mR/h
45	0 mR/h	10.7 mR/h
50	4.8 mR/h	15.7 mR/h
60	0 mR/h	11.1 mR/h
70	0 mR/h	7.5 mR/h
80	4.6 mR/h	6.8 mR/h
90	2.1 mR/h	14.8 mR/h
100	0 mR/h	14.5 mR/h
110	0 mR/h	14.9 mR/h
120	0 mR/h	15.3 mR/h
130	0 mR/h	15.8 mR/h
135	0 mR/h	16.5 mR/h
140	0 mR/h	14.8 mR/h
150	0 mR/h	15 mR/h
160	0 mR/h	0 mR/h
170	0 mR/h	0 mR/h
180	0 mR/h	0 mR/h
190	0 mR/h	0 mR/h
200	0 mR/h	0.7 mR/h
210	0 mR/h	0.9 mR/h
220	0 mR/h	1.8 mR/h
225	1.3 mR/h	2.1 mR/h

Direction °	HD, Adult, 13.5 s	HD, Child, 11.5 s
230	6.2 mR/h	2.4 mR/h
240	1.2 mR/h	6.6 mR/h
250	1.6 mR/h	4 mR/h
260	7.6 mR/h	6.3 mR/h
270	14.8 mR/h	13 mR/h
280	35.4 mR/h	19.6 mR/h
290	19.2 mR/h	20.2 mR/h
300	8.8 mR/h	9.4 mR/h
310	7.1 mR/h	8.6 mR/h
315	6 mR/h	7.4 mR/h
320	6.3 mR/h	6.3 mR/h
330	5.1 mR/h	5.7 mR/h
340	6.3 mR/h	4.6 mR/h
350	4.5 mR/h	4 mR/h



Hersteller / Manufacturer:

DÜRR DENTAL SE
Höpfigheimer Str. 17
74321 Bietigheim-Bissingen
Germany
Fon: +49 7142 705-0
www.duerrdental.com
info@duerrdental.com

